

Review Article

Vitamin D, Calcium to Magnesium, and the Gut Microbiome

Patrick Chambers¹

1. Torrance Memorial Medical Center, Torrance, United States

The gut microbiome has been the subject of increasing interest as integral to our health. Few realize that the enormous benefits of vitamin D (VD) and magnesium (Mg) are highly dependent on a healthy gut microbiome. Short chain fatty acids, especially butyrate, reflect not only a healthy gut microbiome but also VD status. Suboptimal VD, Mg, or butyrate translates to some degree of gut dysbiosis and vice versa. Mg dependent secondary bile acids, indoles, and tryptophan, all microbial metabolites and longevity agents, are also discussed. Mg is indispensable to not only the synthesis of the active form of VD but also that of 7-dehydrocholesterol (7-DHC) from acetate. 7-DHC is the substrate for solar conversion to D₃. The steadily increasing Ca:Mg in the Western diet and its ironic impact on parathormone (PTH) is discussed. Gut dysbiosis further complicates this. Biochemical and physiologic interlinkages are legion and most remain hidden. This limited mini review exposes insight into the tight linkage between 25(OH) D and Ca:Mg, facilitated by the gut microbiome. A model incorporating the physiologically discordant but reinforcing effects on this linkage based on genes, culture, socioeconomic status, and diet that also addresses the seemingly contradictory reports regarding calcium (Ca), Mg, and VD efficacy is proposed.

Introduction

The term VD is often used indiscriminately. VD in this mini review will be used collectively to include its three forms D₃ (cholecalciferol), 25(OH) D (storage form), and 1,25(OH)₂D (active form). VD^[1], Mg^[2], and the products of a healthy gut microbiome, e.g., short chain fatty acids (SCFAs)^[3], secondary bile acids^[4], and indoles^[2], are all longevity agents. They are also intertwined both directly and indirectly. VD regulates Mg status as well as that of Ca and phosphate. Many are familiar with the total dependence of VD efficacy, whether of solar or supplemental origin, on adequate Mg. But the

vital role of the gut microbiome in potentiating both has only recently been revealed. Gut dysbiosis disrupts the balance of beneficial bacteria and impedes the production of many vital nutrients^[5]. Adequacy of the storage form of VD has often been measured relative to parathormone (PTH). But recent research challenges this and raises questions about the impact of Ca:Mg on optimal VD efficacy.

Discussion

I. Vitamin D and Magnesium

VD and Mg are inextricably linked in a bidirectional manner. Through PTH VD can regulate the intestinal absorption and urinary excretion of Ca and Mg^[6]. However, Mg is indispensable to the synthesis of VD. It is generally known that Mg is a required cofactor for every enzymatic step in the conversion of D₃ aka cholecalciferol to its active form 1,25(OH)₂D, including the binding of D or 25(OH) D to VDBP (vitamin D binding protein). However, Mg is also required for the synthesis^[7] and cAMP mediated secretion^[8] of PTH from chief cells in the parathyroid gland. Low plasma Ca driven PTH synthesis stimulates VD synthesis and VD driven high plasma Ca inhibits PTH synthesis. Even more importantly the synthesis of 7-dehydrocholesterol (7-DHC), the immediate precursor of cholecalciferol, from acetate is dependent on Mg (see figure 1). Acetate is provided by either gut microbes or acetyl CoA, which requires Mg dependent B5 (pantothenate). Vitamins B2 and B3 must be phosphorylated to FAD and NAD respectively to attain active status for the synthesis of 7-DHC. This phosphorylation requires ATP and Mg. Without sufficient 7-DHC the sun is powerless to create D₃. This drawback elevates the value of D₃ supplementation versus that provided by the sun, especially in the Mg deficient. Therefore, VD deficiency/insufficiency is a greater risk in the Mg deficient, and sun exposure may not suffice efforts to address the VD shortfall (see figure 1).

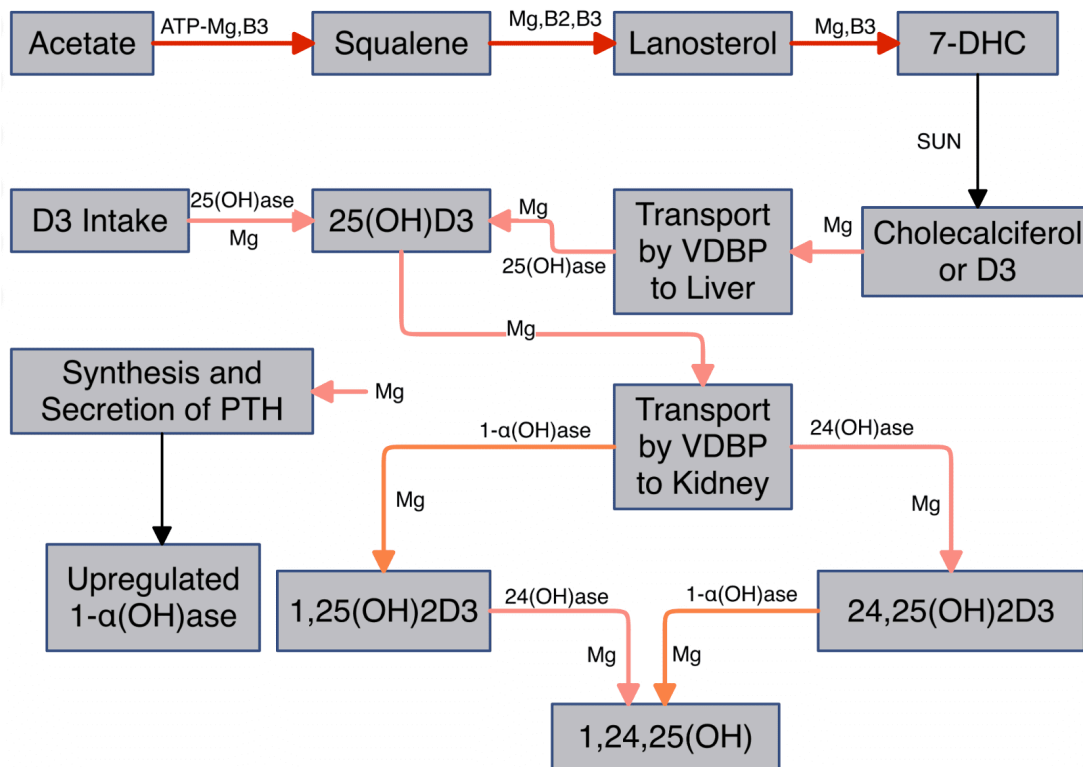

Figure 1. All enzymes that produce the active form of VD (1,25(OH)₂D) from D₃, including binding to the transport protein, synthesis of PTH, and secretion of PTH, are Mg dependent. Many enzymes and cofactors involved in the synthesis of 7-dehydrocholesterol from acetate are also Mg dependent. 7-DHC=7-dehydrocholesterol, VDBP=vitamin D binding protein

Optimal 25(OH) D is at least 50 ng/mL (120 nmol/L), based on clinical data (see figure 2). The 20 and 30 ng/mL 25(OH) D targets generally recommended are suitable only for rickets and skeletal health, but optimal immune function involves intracrine, autocrine, and paracrine pathways and storage form levels that exceed those adequate for endocrine (hormonal) needs. Unfortunately 25(OH) D levels lower than 20 ng/mL are considered deficient and those less than 30 ng/mL are only considered insufficient.

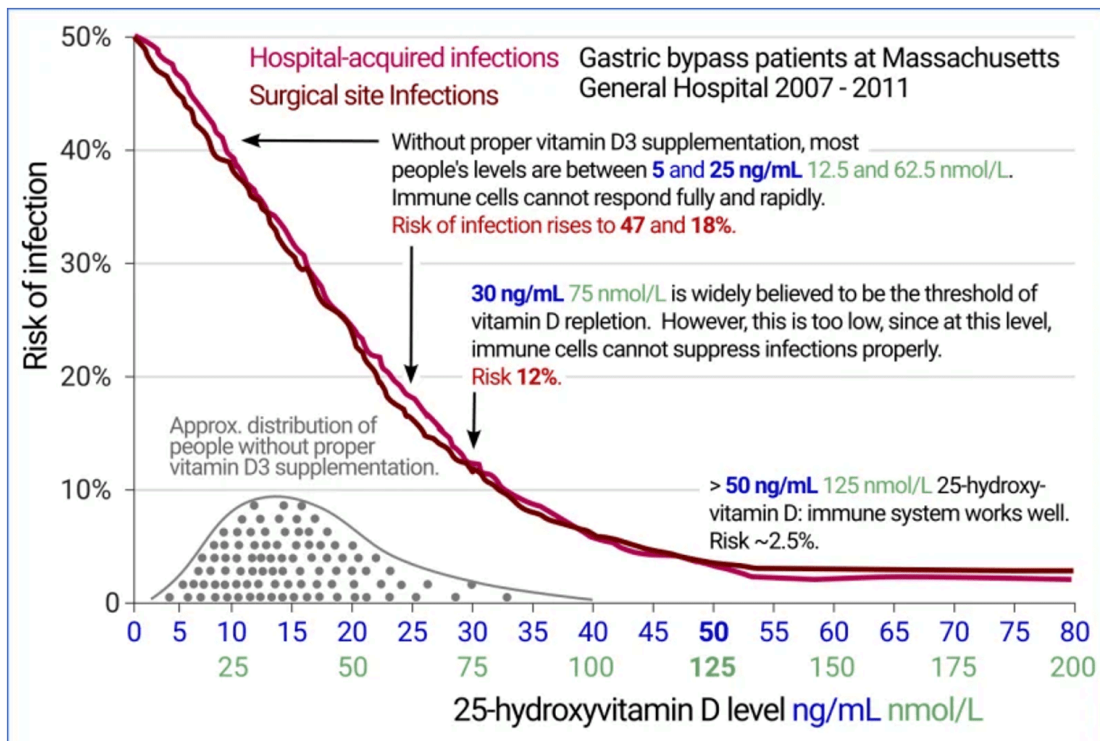

Figure 2. Adapted by Robin Whittle May 2022^[9] from two studies^{[10][11]}. The two colored curves represent VD associated risks for surgical site infection and hospital acquired infection (immune functions of VD) from the gastric bypass study^[10]. The inadequate D3 supplementation distribution figure is from a Covid-19/VD study^[11].

The RDA (Recommended Daily Allowance) of 600–800 IUs D3 per day recommended by the National Academy of Sciences Institute of Medicine (IOM) was proven to be off by an order of magnitude in 2014^[12]. This huge error was confirmed by several Canadian and American university research teams. The IOM’s RDA for VD still stands at 600 IUs to 800 IUs (for adults over 70), but their estimated average requirement (EAR) was subsequently raised from 20 ng/mL to 30 ng/mL. EAR + 2SDs = RDA. An increased intake of an order of magnitude, e.g., 8000 IUs of D3 (cholecalciferol), would correlate with a serum level of at least 50 ng/mL^[13]. NHANES (National Health and Nutrition Examination Surveys) data between 1988 and 2006 revealed little change in mean serum 25(OH) D at about 25 ng/mL^[14]. From 2011 to 2018 median 25(OH) D went from 27 to 27.5ng/mL^[15]. Regarding the cations Ca⁺⁺ and Mg⁺⁺, in the relatively healthy with normal renal function without GI issues and no impacting medications Ca⁺⁺ is usually about 50% of serum values and Mg⁺⁺ is usually about 70% of serum values (see section II). When midrange values of lab reference limits are compared using these

percentages, the resulting ratio for Ca:Mg is very close to 2.0 (serum mmol comparison). Durlach, founder of the International Society for the Development of Research on Magnesium (SDRM), stated in 1989 that optimal Ca and Mg balance was physiologically 2:1^[16]. Serum Mg is not even offered on a routine chemistry panel. Furthermore, in order to avoid normomagnesemic Mg deficiency aka chronic latent Mg deficiency, the lower limit of the normal range for Mg should be raised from 0.75 to 0.85 mM^{[2][17][18][19][20][21]}.

In one study trial participants completed a dietary questionnaire that predicted suboptimal Mg status in 100% of participants. Yet 25% were found to have optimal serum status^[22]. Suboptimal Mg status was defined as serum Mg < 2.0 mg/dL (0.83 mM). Even increasing the lower limit of normal from 0.75 mM to 0.83 mM does not appear to exclude the 25% with optimal serum Mg predicted to be suboptimal by the questionnaire.

II. Calcium to Magnesium Ratio and Vitamin D

Any VD and Mg discussion must include Ca. Serum Ca⁺⁺ triggers negative feedback inhibition of PTH release that directly impacts VD mediated Ca and Mg intestinal absorption and renal resorption. Ca and Mg compete for the calcium sensing receptor (CaSR)^[23], and PTH responds to both cations in the same way but not to the same degree. Yet Mg⁺⁺ often opposes Ca⁺⁺, e.g., as a Ca channel blocker. Because serum Ca is more responsive to VD and the primary determinant of PTH versus Mg, an unbalanced intake of these competing cations can create a dilemma that is almost predictable. An elevated Ca:Mg suppresses PTH, depressing Mg absorption and increasing magnesuria. Mg is an “innocent bystander” to an unbalanced Ca driven suppression of PTH. Mg dependent PTH synthesis and secretion further compromise the Mg shortfall and increase Ca:Mg. The Occidental diet is often relatively short Mg versus Ca and the Oriental diet is often relatively short Ca versus Mg. Poor nutrition and low socioeconomic status may be primary determinants of the ultimate ratio. PTH and VD status are inversely or negatively correlated and produce a hyperbolic curve (see figure 3). However, might the Ca:Mg impact this relationship, given the almost predictable physiologic dilemma previously discussed? Might the secondary hyperparathyroidism in figure 3 be due to hypocalcemia or a low Ca:Mg? On the other hand, might an elevated Ca:Mg create some degree of secondary hypoparathyroidism (see figure 4) not addressed in figure 3? Might a Mg shortfall, compromising PTH and VD synthesis, camouflage a 25(OH) D level of 50 ng/mL obtained primarily through D3 supplementation?

Concentration of Parathyroid Hormone (PTH) as a Function of 25(OH)D (N=14,681)

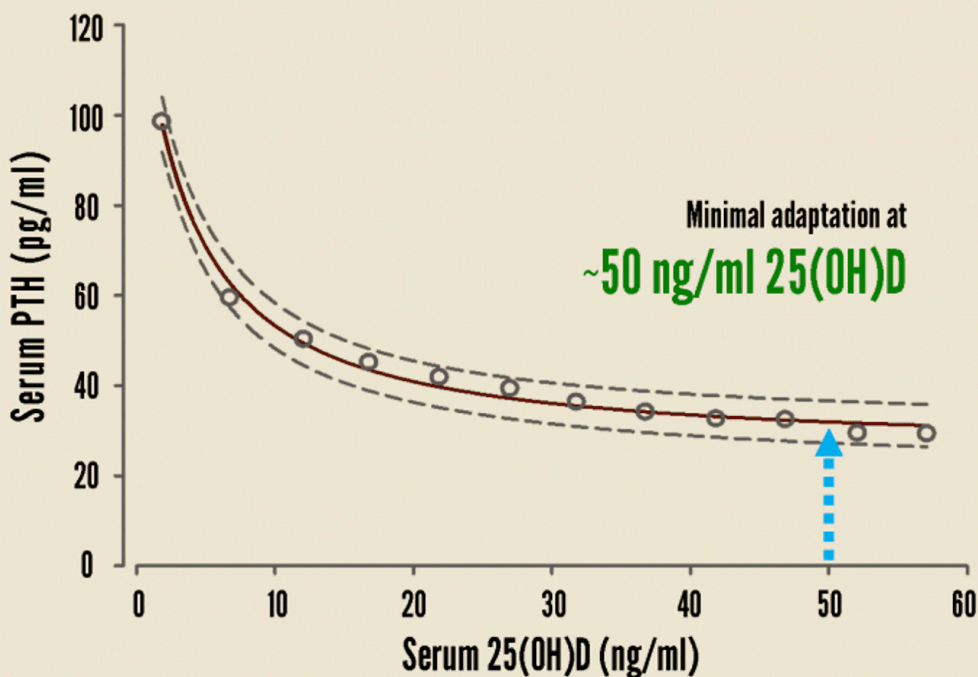

Slide Courtesy of RP Heaney
 ©2017 GrassrootsHealth
 Ginde et al., J. Endocrinol. Invest. (2011)

 **GrassrootsHealth**
 Moving Research into Practice
www.grassrootshealth.org

Figure 3. This figure is from Ginde et al^[24]. Any 25(OH) D value < 50 ng/mL implies some degree of secondary hyperparathyroidism. It also implies that the vast majority of the nearly 15,000 respondents must have a low Ca:Mg (see figure 4).

One relevant study on this^[25] reported that when baseline 25(OH) D exceeded 30 ng/mL, Mg supplementation suppressed 25(OH) D. PTH is not mentioned in that study. However, the Ca:Mg ratios for the placebo and target groups were elevated at 3.9 and 3.7 respectively. This suggests that either Mg supplementation when Ca:Mg is elevated may regrettably suppress PTH and with it VD synthesis or that the additional Mg intake (mean 200 mg) may have exceeded bowel tolerance in a significant number of participants. Any Mg supplementation when Ca:Mg is elevated and 25(OH) D levels exceed that sufficient for skeletal health (30 ng/mL) may be counterproductive and may compromise immune health. Perhaps in addressing an elevated Ca:Mg lowering Ca intake should precede Mg

supplementation. The resistance by the government to increasing the lower limit of the reference range for Mg from 0.75 to 0.85 mmol/L may be fear of its laxative effect. If excess Ca intake is not addressed first, then any increase in Mg intake must still compete for the few available intestinal CaSRs, making the laxative effect hard to avoid.

Other studies support the bell shaped figure 4 conjecture (see figure 5). Lung cancer and CVD are increased whether Ca:Mg is high^{[26][27]} or low^{[27][28]}. VD levels are low in both lung cancer^[29] and CVD^[30]. So, the highly touted benefits of VD may be compromised in those with an unbalanced Ca:Mg. However, a low Ca:Mg and insufficient Ca should trigger PTH secretion, but restrictions due to genes, e.g., skin pigmentation, to culture, e.g., Asian umbrellas, female Arab attire, to socioeconomic status, e.g., poor nutrition, and/or to diet, e.g., lactose intolerance, may conspire to deny the intake of Ca or VD or synthesis of D₃ dependent VD => depressed 25(OH) D, elevated PTH (see figure 3) => secondary hyperparathyroidism. The inverse relationship between PTH and 25(OH) D (left wing in figure 4) may pivot around the optimal zone (see figure 5) with transition to a direct relationship (right wing in figure 4) => secondary hypoparathyroidism. The vertical axis in figure 4 may also directly reflect gut microbiome quality and optimal health (see figure 5).

Figure 4 represents a hypothetical view of this based on

1. Increasing Ca intake when Ca:Mg is less than 1.7 decreases risk for some cancers^{[31][32]}.
2. Increasing Mg intake when Ca:Mg is less than 1.7 increases risk for some cancers^[31].
3. An elevated Ca to Mg ratio increases risks for some cancers, including lung cancer^[26], and CVD^[27].
4. A depressed Ca to Mg ratio increases risks for some cancers, including lung cancer^[28], and CVD^[27].
5. Low Mg in the setting of elevated Ca:Mg translates to low VD^[33]. This can be explained physiologically, as Mg is required for the synthesis and secretion of PTH and for the synthesis of VD. Elevated Ca also displaces Mg from CaSRs.
6. Low Ca in the setting of depressed Ca:Mg is physiologically contradictory to a concomitant low VD. However, this may be explained based on discrepant but mutually reinforcing genetic, cultural, socioeconomic, and dietary considerations. These may complicate and compromise clinical correlations and data analysis.
7. Skin pigmentation is directly linked to VD deficiency^[34].

8. Socioeconomic status is directly linked to VD deficiency^{[35][36]}. D3 is not in the budget or on the menu.
9. Cultural customs can drive VD deficiency. Most in the Middle East dress modestly^[37] and many Asians are averse to solar exposure.
10. Diet is largely dependent on culture. The South Asian diet is low in VD rich foods^[38] and many Asians are lactose intolerant and avoid dairy products^[39], excellent sources of Ca and VD.

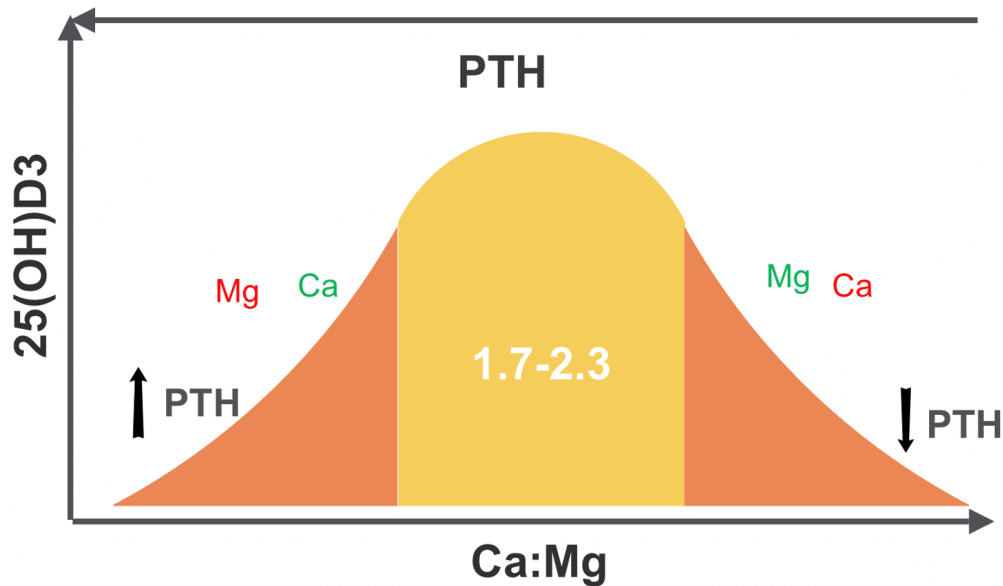

Figure 4. This hypothetical bell shaped curve delineates the proposed relationships between VD, Ca:Mg, and PTH. Yellow represents the target range and orange the health risk ranges for Ca:Mg, when physiologic considerations and genetic, cultural, socioeconomic, and dietary considerations are separated. The left wing is suboptimal and represents some degree of secondary hyperparathyroidism due to hypocalcemia (Ca<lower limit, Mg</=lower limit), while the right wing is also suboptimal and represents some degree of secondary hypoparathyroidism due to chronic latent Mg deficiency or hypomagnesemia (Ca</=lower limit, Mg<lower limit).

Figure 4 illustrates a proposed shift in VD supplementation from one viewed through PTH to one viewed through Ca:Mg. The balance between Ca and Mg is increasingly recognized as critical to attaining optimal levels of 25(OH) D. The left wing represents some degree of secondary hyperparathyroidism due to hypocalcemia, while the right wing represents some degree of secondary

hypoparathyroidism due to chronic latent Mg deficiency or hypomagnesemia. Insufficient Mg translates to insufficient Mg dependent PTH synthesis, insufficient PTH induced Ca absorption/resorption, and insufficient Mg dependent VD synthesis => depressed 25(OH) D and PTH. Increasing Mg intake should elevate both 25(OH) D and PTH. But this doesn't happen, when 25(OH) D exceeds 30 ng/mL and Ca:Mg exceeds 3.7^[25]. The 3.7 Ca:Mg ratio in this article was based on a food frequency questionnaire that predicted Ca and Mg values relative to their RDAs. Serum values for these two elements are generally reported in mg/dL, but mmol/L units are more physiologically relevant. Conversion yields Ca:Mg of 2.22 (3.7x 24/40). However, only the unbound or ionic form is physiologically active. If one compares the normal ranges for serum Mg and Ca with the normal ranges for ionized Mg and ionized Ca, they closely align, but only if Mg⁺⁺ and Ca⁺⁺ represent 70% and 50% of total serum levels respectively. That 50% of serum Ca is unbound is generally accepted, but for Mg⁺⁺ there's a spread of 55-70%. So, in a relatively healthy individual the figure for Mg must be close to 70%. When the midpoints of the ranges for the ionized forms, 0.6 mM for Mg^[40] and 1.19 mM for Ca⁺⁺(9.5mg/40mg) x50%, the Ca:Mg is 1.98, very much in line with Durlach's recommendation^[16]. His designation of 2.0 was based on research into the physiological roles and interactions of these minerals in the body, not on a questionnaire. Figure 3 recognizes only the left wing of the bell. Regarding the upper limit of the optimal range, one study^[41] favored an upper limit of 2.8 (see figure 5). Adjusted for their unbound or ionic forms, 2.8 Ca:Mg translates to 2.0 iCa:iMg. A study on a large Chinese population revealed a minimum Ca:Mg of 1.7 as optimal^[42]. This is corroborated by two Chinese studies^{[43][44]} that recommended reference ranges for Ca:Mg between 1.7 and 2.5.

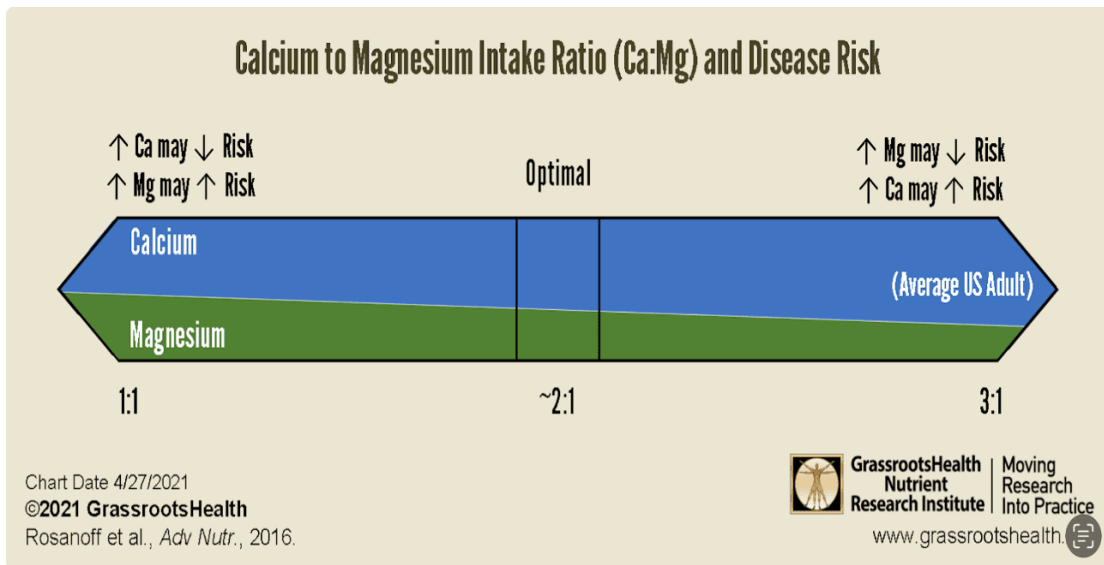

Figure 5. This figure is from Rosanoff et al.^[41] Disease risk, an inverse proxy for VD status, increases as the Ca:Mg increases or decreases. However, increasing Mg with Ca:Mg greater than 2.8 and 25(OH) D greater than 30 ng/mL may not reduce risk^[25], unless excess Ca intake is addressed first.

VD deficiency may be at the root of many health issues exacerbated by a Ca:Mg ratio outside the 1.7–2.8 range^[41]. The failure to normalize for Ca:Mg in any study on the efficacy of VD may compromise any conclusions and may sell short the value of this extraordinary micronutrient (see figure 4). Recent data from NHANES on Ca:Mg based on combined dietary and supplemental intake is sparse. Figure 6 was derived from 2001–23 NHANES data for both genders over age 20, diet only^[45]. NHANES data from 2001–2006^[33] yielded a mean daily Ca supplement of 251mg and a mean daily Mg supplementation of 65mg. Total Ca and Mg intake was then derived. The results suggest that many Americans may be susceptible to health risks linked to hypoparathyroidism and low PTH that may compromise the efficacy of VD (see figures 4,5), especially if 25(OH) D exceeds 30 ng/mL^[25].

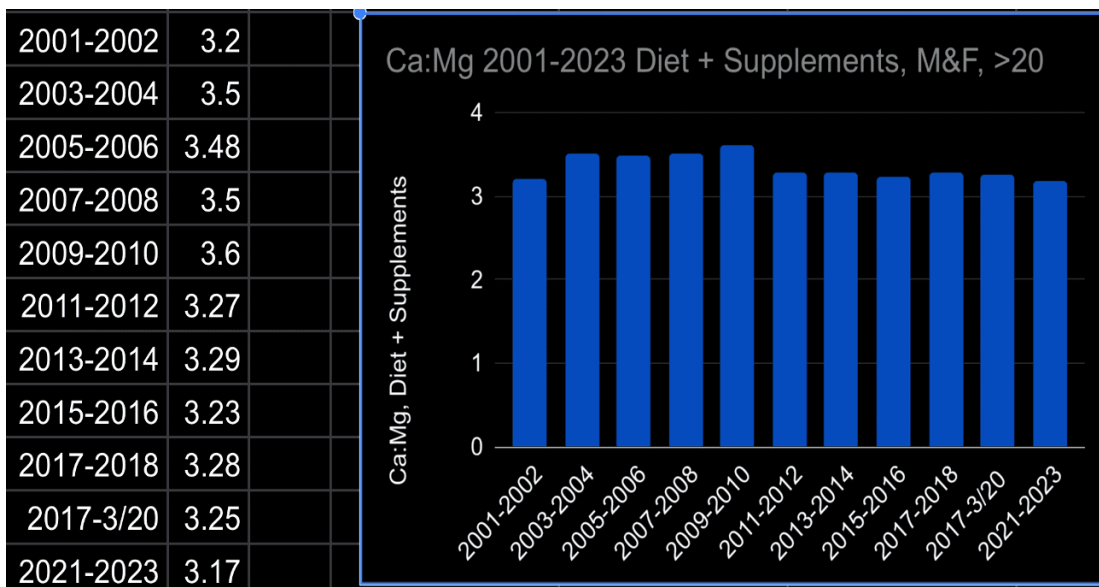

Figure 6. This step graph represents a derived approximation of Ca:Mg, using Ca and Mg dietary intake only data from 2001–2023, both genders, age greater than 20. To this was added the mean Ca and Mg supplementation only data (Ca 251 mg/d and Mg 65 mg/d) from 2001–2006 both genders, all ages. These ratios were much worse in those ages 6–19 years, usually exceeding 4.0.

43 is gone

44 is covid severity

The Covid-19 epidemic demonstrated the importance of this ratio, as low Mg intake was tightly linked to Covid severity^[46]. A pre-Covid study on high dose D3 for critically ill patients reported no benefit^[47]. Ca:Mg status was not reported and magnesium was not mentioned. Might D3 therapy exacerbate an elevated Ca:Mg? An elevated ratio does not exclude low levels of one or both cations.

III. Vitamin D and the Gut Microbiome

Although the active form of VD mediates its endocrine, intracrine, autocrine, and paracrine effects, D3 contributes additional benefits. D3 inhibits Candida hyphal morphogenesis^{[48][49]}. The emerging role of the gut microbiome in health and disease and the impact of Candida overgrowth in gut dysbiosis highlights the value of D3. Candida overgrowth can be both cause and effect of gut dysbiosis^[50]. In addition the active form 1,25(OH)₂D, but not its storage form 25(OH) D, most frequently requested lab analyte, is linked to an abundance of butyrate producing bacteria^[51], frequently linked to gut health.

In fact the active form of VD correlated even more tightly with microbiome diversity. These reported results were adjusted for solar exposure. The active form of VD increases the Bacteroidetes/Firmicutes ratio, especially Akkermansia and Faecalibacterium of the Bacteroidetes phylum, both prominent butyrate producers^[52], and increases microbial diversity^[53]. VD deficiency and suboptimal gut microbiome are associated with cancer^[54], autoimmune disease^[55], inflammatory bowel disease,^[56] cystic fibrosis^[57], multiple sclerosis^[58], diabetes^{[59][60]}, and depression^[61]. Butyrate has an ameliorative effect on dementia^[62], cancer prevention/treatment^[63], especially colorectal cancer^[64], and obesity^[65]. The SCFAs acetate, propionate and butyrate are produced from the microbial fermentation of indigestible carbohydrates and are the biomarkers of a healthy gut microbiome^[66]. Acetate and propionate producing bacteria can cross feed butyrate-producing bacteria^[67].

But improvements in the gut microbiome via increasing D3 supplementation in those already deficient/insufficient are not limited to the symptomatic. Increased serum 25(OH) D was associated with increased beneficial bacteria and decreased pathogenic bacteria^[68]. D3 is both therapeutic and prophylactic and appears to possess prebiotic properties^[69]. The well known skeletal benefits of VD are in part mediated by butyrate. Butyrate stimulates osteoblastic activity and down-regulates osteoporosis^[69], possibly by stimulating the release of PTH^[70]. The opposite is also true. Gut dysbiosis is linked with suboptimal VD status^[71]. The gut microbiome regulates not only bone homeostasis and bone health^[72] but also many extraskelatal functions of VD, e.g., anti cancer, anti diabetes, anti hypertension, anti obesity, anti dementia, anti autoimmunity. Dysbiosis compromises the absorption of D3, Ca, and Mg. The gut Firmicutes/Bacteroidetes ratio is negatively linked to a healthy gut microbiome^[73] with suppression of Firmicutes phylum bacteria upon supplementation with 25(OH) D or D3^[74]. VD deficiency also negatively impacts the gut microbiome, compromising B vitamin production. While Mg is required for activation of B2,3,6,9,12, the gut microbiome may fill in for any shortfall^[75]. Some intestinal bacteria can produce all eight B vitamins^[76] and up to 65% of human gut microorganisms can synthesize at least one type of B vitamin^[77]. The few discrepant reports on the efficacy of D3 with respect to the gut microbiome may be due to:

1. Lack of baseline data indicating insufficiency/deficiency
2. Failure to properly separate placebo and target groups by baseline
3. Less than 2-3 months between start of D3 supplementation and measurement of results
4. Insufficient D3 dosage

5. Failure to normalize for Ca:Mg as a confounding factor
6. Target group too small

IV. Magnesium and the Gut Microbiome

Primary bile acids are metabolized by Mg dependent CYP450 (Cytochrome P450) enzymes^[78] and impact the gut microbiome^[79]. Primary bile acids are metabolized to secondary bile acids by intestinal bacteria. Secondary bile acids, associated with longevity, are also Mg dependent^[80] and require a healthy gut microbiome. Both SCFAs and secondary bile acids independently exert a myriad of beneficial effects on host health^[81]. Recently the vital role of aryl hydrocarbon receptors (AhRs) in aging^[82], dementia, autoimmune disease, cancer^[83], and ASCVD^[84] has been recognized. AhR activity is dependent on its ligands. Kynurenines are AhR ligands that accelerate aging and neurodegeneration, while butyrates and indoles of intestinal bacterial origin are AhR ligands that oppose this^[82] and promote longevity. Indoles are longevity agents produced by gut microbiota. Their healthful benefits depend on the aryl hydrocarbon receptor (AhR)^[85]. Not only are indoles and butyrate AhR ligands^[86], but their subsequent AhR activation induces Mg dependent cytochrome CYP450 enzymes that facilitate gut absorption of indoles^[87]. All CYP450 enzymes are Mg dependent^[74]. Like Ozempic, butyrate is also a GLP-1 (glucagon-like peptide) agonist^[88], albeit a natural one. Both are longevity indicators. Probiotics, rich in butyrogenic bacteria, are also associated with longevity^[89] and Mg enhances their efficacy^[90]. Butyrate produced by gut bacteria may via vagal afferents increase HRV^{[91][92]}, linked to longevity. Gut microbiota cannot produce SCFAs in the absence of Mg^[93], but they can produce tryptophan^[94], another longevity agent. Candida yeast and hyphal forms produce their own form of IDO^[95] that competes with host IDO. It enhances degradation of tryptophan to kynurenine (K/T) and accelerates the kynurenine pathway, increasing K/T, especially under the direction of interferon-gamma^[96]. Any shortfall in Mg can increase subsequent neurotoxic metabolites and decrease NAD⁺ production^[2]. The K/T ratio is negatively linked to the health of the gut microbiome^[96]. Lactobacilli and Bifidobacteria boost plasma tryptophan levels^[90]. They also produce lactate, which can crossfeed butyrogenic bacteria^[97]. Gut microbes provide most of our circulating tryptophan. However, in order to absorb it intestinal epithelial cells rely on B⁰AT, a neutral or nonpolar amino acid transporter, that works in concert with ACE2 receptors^[98]. This puts those

with Covid-19, long Covid, or Candida overgrowth at risk for gut dysbiosis, compromising the enormous benefits of VD and Mg.

V. Therapeutic Interventions (see figure 7)

1. Probiotics, e.g., yogurt, alone are insufficient, if diet is suboptimal. The “good” bacteria must be fed and require fiber or indigestible carbohydrates, i.e., prebiotic, e.g., d-mannose. Butyrate is a commercially available postbiotic (produced by the “good” bacteria) that mimics the actions of Ozempic.
2. Target 2.0 for iCa:iMg or a maximum of 2.8 Ca:Mg in mmoles. If elevated, lower dietary Ca, e.g., dairy products, first and then increase dietary Mg, e.g., nuts, seeds, leafy greens, avocados. The silent damage overtime due to an elevated ratio escapes detection and the laxative effect of Mg facilitates this. Figure 3 indicates that Ca:Mg in the “healthy” has well exceeded 3.0 Ca:Mg for at least two decades. Chronic latent Mg deficiency remains hidden, when the lower limit of normal persists at 0.75 mmol/L.
3. After improving Ca:Mg supplement D3 to attain a serum level of at least 50 ng/mL (125 mM) 25(OH) D (see figure 7)^{[99][100]}.
4. Take supplemental Mg with pyridoxal phosphate, the active form of B6, and perhaps D3. Mg is required for the hydroxylation of D3 in the liver (storage form). Taking pyridoxal phosphate concomitantly with Mg can enhance absorption and availability of Mg^{[101][102]}. Not only does pyridoxal phosphate enhance cellular uptake of Mg but Mg enhances that of pyridoxal phosphate^[103]. Several studies have challenged this^{[104][105]}. But both studies employed the inactive form - pyridoxine.
5. Avoid simultaneous Ca and Mg intake. Although CaSRs are primarily found in the parathyroid gland and the kidney, they are also present in many other organs, including the alimentary canal^[106].
6. Avoid simultaneous processed food/soft drinks and Mg intake. The former contain phosphates, which bind Mg, limiting absorption.
7. Exercise induced elevation of lactate may enhance serum butyrate. Lactate may permeate intestinal endothelial and epithelial cells into the alimentary canal, where it can crossfeed butyrogenic bacteria^[97].

8. Pay close attention to proper hydration. Dehydration triggers release of aldosterone, which increases renal reabsorption of Na^+ and urinary excretion of Mg^{++} and K^+ . Cortisol possesses similar aldosterone properties and can to a lesser degree trigger this same cationic exchange. Stress induced cortisol can lead to Mg deficiency, while Mg deficiency in turn enhances the body's susceptibility to stress^[107].
9. Increase VD intake with age and increasing morbidity.
10. Replenish water soluble B vitamins that require Mg for activation and are required for synthesis of 7-dehydrocholesterol from acetate, enabling solar conversion to D3, (see figure 1).

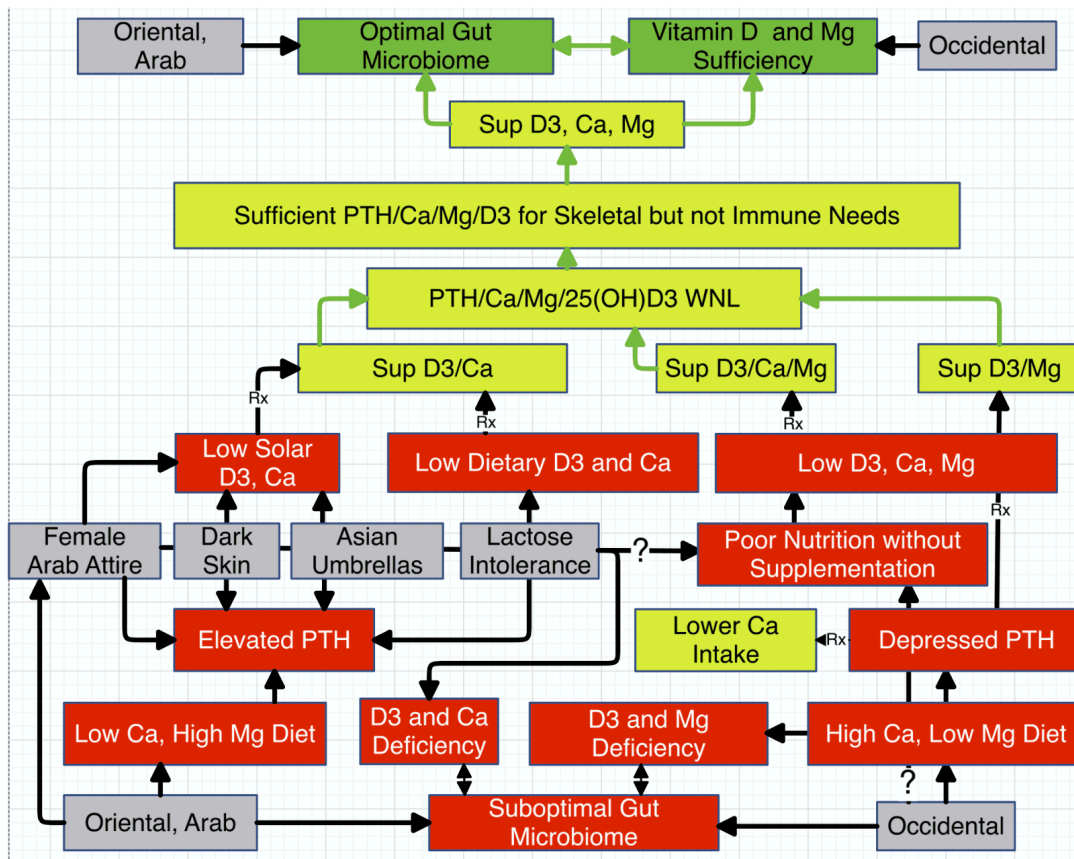

Figure 7. This illustrates a proposed flowchart for deficiencies of VD, Ca, and Mg in various racial, ethnic, cultural, and economic sub groups, many of which overlap. Flow from a suboptimal gut microbiome at the bottom in red through a suggested therapeutic approach in yellow to an optimal gut microbiome and balanced Ca:Mg (green) is indicated. Rx=therapy, Sup=supplementation

Conclusion

Mg may be to VD what the gut microbiome is to general health. One is indispensable to the other. This review presents the benefits of both to gut microbiome dependent longevity agents. Many indirect benefits of this partnership are not included, e.g., maintenance of intestinal integrity^{[90][108]}. VD and Mg are inextricably entwined and work hand in glove. Thirty ng/mL of 25(OH) D and 0.75 mg/dL of Mg are insufficient. Mg is indispensable for not only the synthesis of VD's solar substrate (D3) and the storage/active forms of VD from D3 but also the synthesis and secretion of PTH. A healthy gut microbiome is also required to fully realize the benefits of both. Furthermore, there are many other gut microbiome related micronutrients and vitamins that depend on VD and Mg for their healthful effects and vice versa. Indeed there are myriad extraskeletal and extra-intestinal benefits of both. The interdependencies are both legion and complex. Many have only recently been discovered and much remains hidden. This review is largely hypothetical and highlights the relevant physiology, while overlooking the massive role of genes. The contributions of the gut microbiome are massively underappreciated. The increasingly sedentary Western lifestyle, the deteriorating quality of food, the abundant use of antibiotics and certain other medications, e.g., proton pump inhibitors and some diuretics, have conspired to challenge the quality of our gut microbiome. Not surprisingly the benefits of fecal microbiota transplantation (FMT) have rapidly expanded from its initial treatment for fulminant pseudomembranous colitis due to *Clostridium difficile* to an emerging tool for alleviating diseases related to a problematic gut microbiome. Gut microbiome manipulation and FMT may eventually become the frontline therapeutic approach to all diseases from cancer and dementia to Lyme disease. VD, Ca, and Mg are majority players in this manipulation along with prebiotics + probiotics (synbiotics) and postbiotics. VD efficacy is tightly linked to Ca:Mg and VD studies that adjust for race, ethnicity, culture, socioeconomic status, and diet may even reveal greater efficacy. Unfortunately many of these conditions overlap in complex ways and difficulties in evaluating Mg status make this a challenging proposition. This speculative view of VD efficacy is supported by many recent Covid-19 driven reports and relevant laboratory data. However, robust analysis of clinical correlations awaits.

References

1. [^]Fantini C, Corinaldesi C, Lenzi A, Migliaccio S, Crescioli C. "Vitamin D as a Shield against Aging." *International Journal of Molecular Sciences*. 2023; 24(5):4546. doi:10.3390/ijms24054546.
2. [^][^][^][^]Chambers P. "Magnesium and Longevity." *Qeios*. 2024. doi:10.32388/N1SCBR.3.
3. [^]Badal VD, Vaccariello ED, Murray ER, Yu KE, Knight R, Jeste DV, et al. "The Gut Microbiome, Aging, and Longevity: A Systematic Review." *Nutrients*. 2020; 12(12):3759. doi:10.3390/nu12123759.
4. [^]Bidell MR, Hobbs ALV, Lodise TP. "Gut microbiome health and dysbiosis: A clinical primer." *Pharmacotherapy*. 2022 Nov; 42(11):849–857. doi:10.1002/phar.2731.
5. [^]Martinez JE, Kahana DD, Ghuman S, Wilson HP, Wilson J, Kim SCJ, et al. "Unhealthy Lifestyle and Gut Dysbiosis: A Better Understanding of the Effects of Poor Diet and Nicotine on the Intestinal Microbiome." *Front Endocrinol (Lausanne)*. 2021 Jun 8; 12:667066. doi:10.3389/fendo.2021.667066.
6. [^]Norman DA, Fordtran JS, Brinkley LJ, Zerwekh JE, Nicar MJ, Strowig SM, et al. "Jejunal and ileal adaptation to alterations in dietary calcium: changes in calcium and magnesium absorption and pathogenetic role of parathyroid hormone and 1,25-dihydroxyvitamin D." *J Clin Invest*. 1981 Jun; 67(6):1599–603. doi:10.1172/jci110194.
7. [^]Mahaffee DD, Cooper CW, Ramp WK, Ontjes DA. "Magnesium promotes both parathyroid hormone secretion and adenosine 3',5'-monophosphate production in rat parathyroid tissues and reverses the inhibitory effects of calcium on adenylate cyclase." *Endocrinology*. 1982 Feb; 110(2):487–95. doi:10.1210/endo-110-2-487.
8. [^]Brown EM, Hurwitz S, Aurbach GD. "Beta-adrenergic stimulation of cyclic AMP content and parathyroid hormone release from isolated bovine parathyroid cells." *Endocrinology*. 1977 Jun; 100(6):1696–702. doi:10.1210/endo-100-6-1696.
9. [^]Figure 2 graph of infection versus 25(OH) D level may be viewed at <https://vitamindstops covid.info/02-intracrine/>
10. [^][^][^]Quraishi SA, Bittner EA, Blum L, Hutter MM, Camargo CA. "Association Between Preoperative 25-Hydroxyvitamin D Level and Hospital-Acquired Infections Following Roux-en-Y Gastric Bypass Surgery." *JAMA Surg*. 2014; 149(2):112–118. doi:10.1001/jamasurg.2013.3176.
11. [^][^][^]Israel A, Cicurel A, Feldhamer I, et al. "The link between vitamin D deficiency and Covid-19 in a large population." *medRxiv*; 2020. doi:10.1101/2020.09.04.20188268.

12. [△]Veugelers PJ, Ekwaru JP. "A statistical error in the estimation of the recommended dietary allowance for vitamin D." *Nutrients*. 2014, 6, 4472–4475. doi:10.3390/nu6104472.
13. [△]Chambers P. "Comment on Huțanu et al. Low Serum Vitamin D in COVID-19 Patients Is Not Related to Inflammatory Markers and Patients' Outcomes—A Single-Center Experience and a Brief Review of the Literature." *Nutrients*. 2022, 14, 1998. doi:10.3390/nu14163387.
14. [△]Sempos CT, Looker AC, Durazo-Arvizu RA, Yetley EA, Chaudhary-Webb M, Maw KL, et al. "The vitamin D status of the US population from 1988 to 2010 using standardized serum concentrations of 25-hydroxyvitamin D shows recent modest increases." *Am J Clin Nutr*. 2016 Aug; 104(2):454–61. doi:10.3945/ajcn.115.127985.
15. [△]Subramanian A, Burrowes HB, Rumph JT, Wilkerson J, Jackson CL, Jukic AMZ. "Vitamin D Levels in the United States: Temporal Trends (2011–2018) and Contemporary Associations with Sociodemographic Characteristics (2017–2018)." *Nutrients*. 2024 Oct 9; 16(19):3414. doi:10.3390/nu16193414.
16. [△]Durlach J. "Recommended dietary amounts of magnesium: Mg RDA." *Magnes Res*. 1989 Sep; 2(3):195–203. <https://pubmed.ncbi.nlm.nih.gov/2701269/>
17. [△]Costello RB, Rosanoff A, Dai Q, Saldanha LG, Potischman NA. "Perspective: Characterization of Dietary Supplements Containing Calcium and Magnesium and Their Respective Ratio—Is a Rising Ratio a Cause for Concern?" *Adv Nutr*. 2021 Mar 31; 12(2):291–297. doi:10.1093/advances/nmaa160.
18. [△]Razzaque MS. "Magnesium: Are We Consuming Enough?" *Nutrients*. 2018; 10(12):1863. doi:10.3390/nu10121863.
19. [△]Elin RJ. "Assessment of magnesium status for diagnosis and therapy." *Magnes Res*. 2010 Dec; 23(4):S194–8. doi:10.1684/mrh.2010.0213
20. [△]Micke O, Vormann J, Kraus A, Kisters K. "Serum Magnesium: Time for a Standardized and Evidence-Based Reference Range." *Magnetic Resonance*. 2021; 34:84–89. https://www.magnesium-ges.de/Micke_et_al_2021.pdf
21. [△]Rosanoff A, West C, Elin RJ, Micke O, Baniasadi S, Barbagallo M, et al. "MaGNet Global Magnesium Project (MaGNet). Recommendation on an updated standardization of serum magnesium reference ranges." *Eur J Nutr*. 2022 Oct; 61(7):3697–3706. doi:10.1007/s00394-022-02916-w.
22. [△]Weiss D, Brunk DK, Goodman DA. "Scottsdale Magnesium Study: Absorption, Cellular Uptake, and Clinical Effectiveness of a Timed-Release Magnesium Supplement in a Standard Adult Clinical Population." *J Am Coll Nutr*. 2018; 37(4):316–327. doi:10.1080/07315724.2017.1398686.

23. [△]Quinn SJ, Thomsen AR, Egbuna O, Pang J, Baxi K, Goltzman D, et al. "CaSR-mediated interactions between calcium and magnesium homeostasis in mice." *Am J Physiol Endocrinol Metab*. 2013 Apr 1; 304(7):E724-33. doi:10.1152/ajpendo.00557.2012.
24. [△]Ginde AA, Wolfe P, Camargo CA Jr, Schwartz RS. "Defining vitamin D status by secondary hyperparathyroidism in the U.S. population." *J Endocrinol Invest*. 2012 Jan; 35(1):42-8. doi:10.3275/7742
25. [△]_{a, b, c, d}Dai Q, Zhu X, Manson JE, Song Y, Li X, Franke A, et al. "Magnesium Status and Supplementation Influence Vitamin D Status and Metabolism: Results from a Randomized Trial." *The American Journal of Clinical Nutrition*. 2018; 108:1249-1258. doi:10.1093/ajcn/nqy274.
26. [△]_bShah SC, Dai Q, Zhu X, Peek RM Jr, Roumie C, Shrubsole MJ. "Associations between calcium and magnesium intake and the risk of incident oesophageal cancer: an analysis of the NIH-AARP Diet and Health Study prospective cohort." *Br J Cancer*. 2020 Jun; 122(12):1857-1864. doi:10.1038/s41416-020-0818-6.
27. [△]_{a, b, c, d}Han C, Shin A, Lee J, et al. "Dietary calcium intake and the risk of colorectal cancer: a case control study." *BMC Cancer*. 2015; 15, 966. doi:10.1186/s12885-015-1963-9.
28. [△]_{a, b}Takata Y, Yang JJ, Yu D, Smith-Warner SA, Blot WJ, White E, et al. "Calcium Intake and Lung Cancer Risk: A Pooled Analysis of 12 Prospective Cohort Studies." *J Nutr*. 2023 Jul; 153(7):2051-2060. doi:10.1016/j.tjnut.2023.03.011.
29. [△]Huang JH, Tsai LC, Chang YC, et al. "High or low calcium intake increases cardiovascular disease risks in older patients with type 2 diabetes." *Cardiovasc Diabetol*. 2014; 13, 120. doi:10.1186/s12933-014-0120-0.
30. [△]Hongwen T, Wei G, Quanwei H, Mengjun B, Yingjiu J. "Research Progress on the Relationship between Vitamin D and Lung Cancer." *J Clin Med Surgery*. 2024; 4(1): 1148. <https://jclinmedsurgery.com/articles/jcms-v4-1148.html>
31. [△]_bHaider F, Ghafoor H, Hassan OF, Farooqui K, Bel Khair AOM, Shoaib F. Vitamin D and Cardiovascular Diseases: An Update. *Cureus*. 2023 Nov 30;15(11):e49734. doi:10.7759/cureus.49734.
32. [△]Yoon HS, Shu XO, Cai H, Zheng W, Blot WJ, Cai Q. Abstract 851: Associations of dietary calcium and magnesium intakes with lung cancer risk among low-income Americans: Results from the Southern Community Cohort Study. *Cancer Research*. 2021 Jul 1;81(13_Supplement):851. doi:10.1158/1538-7445.am2021-851.
33. [△]_{a, b}Deng X, Song Y, Manson JE, Signorello LB, Zhang SM, Shrubsole MJ, Ness RM, Seidner DL, Dai Q. Magnesium, vitamin D status and mortality: results from US National Health and Nutrition Examination S

- urvey (NHANES) 2001 to 2006 and NHANES III. *BMC Medicine*. 2013;11:187. doi:10.1186/1741-7015-11-187.
34. [△]Batai K, Cui Z, Arora A, Shah-Williams E, Hernandez W, Ruden M, et al. Genetic loci associated with skin pigmentation in African Americans and their effects on vitamin D deficiency. *PLOS Genetics*. 2021;17(2):e1009319. doi:10.1371/journal.pgen.1009319.
 35. [△]Scully H, Laird E, Healy M, Crowley V, Walsh JB, McCarroll K. Socioeconomic status predicts vitamin D status in a large cohort of Irish children. *Proceedings of the Nutrition Society*. 2022;81(OCE4):E87. doi:10.1017/S0029665122001161.
 36. [△]Tønnesen R, Hovind PH, Jensen LT, Schwarz P. Determinants of vitamin D status in young adults: influence of lifestyle, sociodemographic and anthropometric factors. *BMC Public Health*. 2016;16:385. doi:10.1186/s12889-016-3042-9.
 37. [△]Hussein DA, Ahmed G, Ahmed S, Salih R, Kakamad F, Salih A, Hama Amin B, Abdalla B, Mohammed S, Salim R, Hamarrahim S, Hamid S, Hamarashid A, Rashid C, Hamadameen W, Salih K. Pattern of vitamin D deficiency in a Middle Eastern population: A cross-sectional study. *International Journal of Functional Nutrition*. 2022. doi:10.3892/ijfn.2022.30.
 38. [△]Darling AL, Blackburn DJ, Ahmadi KR, Lanham-New SA. Very High Prevalence of 25-hydroxyvitamin D Deficiency in 6433 UK South Asian adults: analysis of the UK Biobank Cohort. *British Journal of Nutrition*. 2020. doi:10.1017/S0007114520002779.
 39. [△]Chan CY, Mohamed N, Soelaiman IN, Chin KY. Attitude of Asians to Calcium and Vitamin D Rich Foods and Supplements: A Systematic Review. *Sains Malaysiana*. 2018. doi:10.17576/jsm-2018-4708-19.
 40. [△]Altura BM. Introduction: importance of Mg in physiology and medicine and the need for ion selective electrodes. *Scand J Clin Lab Invest Suppl*. 1994;217:5-9. <https://pubmed.ncbi.nlm.nih.gov/7939385/>.
 41. ^{a, b, c}Rosanoff A, Dai Q, Shapses SA. Essential Nutrient Interactions: Does Low or Suboptimal Magnesium Status Interact with Vitamin D and/or Calcium Status? *Advances in Nutrition*. 2016 Jan 15;7(1):25-43. doi:10.3945/an.115.008631.
 42. [△]Dai Q, Shu XO, Deng X, Xiang YB, Li H, Yang G, Shrubsole MJ, Ji B, Cai H, Chow WH, Gao YT, Zheng W. Modifying effect of calcium/magnesium intake ratio and mortality: a population-based cohort study. *B MJ Open*. 2013 Feb 20;3(2):e002111. doi:10.1136/bmjopen-2012-002111.
 43. [△]Zhang H, Cao Y, Song P, Man Q, Mao D, Hu Y, Yang L. Suggested Reference Ranges of Blood Mg and Ca Level in Childbearing Women of China: Analysis of China Adult Chronic Disease and Nutrition Surveillance (2015). *Nutrients*. 2021 Sep 20;13(9):3287. doi:10.3390/nu13093287.

44. [△]Yang J, Cao Y, Shan X, Zhang H, Feng J, Lu J, et al. The Magnesium Status and Suggested Reference Ranges of Plasma Magnesium, Calcium, and Calcium/Magnesium Ratio in Chinese Adults over 45 Years Old. *Nutrients*. 2023 Feb 9;15(4):886. doi:10.3390/nu15040886.
45. [△]NHANES data for nutrient intake by gender and age from 2001 through Aug 2023. <https://www.ars.usda.gov/northeast-area/beltsville-md-bhnrc/beltsville-human-nutrition-research-center/food-surveys-research-group/docs/wweia-data-tables/>.
46. [△]Nouri-Majd S, Ebrahimzadeh A, Mousavi SM, Zargarzadeh N, Eslami M, Santos HO, et al. Higher Intake of Dietary Magnesium Is Inversely Associated With COVID-19 Severity and Symptoms in Hospitalized Patients: A Cross-Sectional Study. *Frontiers in Nutrition*. 2022 May 12;9:873162. doi:10.3389/fnut.2022.873162.
47. [△]Ginde AA, Brower RG, Caterino JM, Finck L, Banner-Goodspeed VM, Grissom CK, et al. Early High-Dose Vitamin D3 for Critically Ill, Vitamin D-Deficient Patients. *New England Journal of Medicine*. 2019 Dec 26;381(26):2529-2540. doi:10.1056/NEJMoa1911124.
48. [△]Kherad Z, Yazdanpanah S, Saadat F, Pakshir K, Zomorodian K. Vitamin D3: A promising antifungal and antibiofilm agent against *Candida* species. *Curr Med Mycol*. 2023 Jun;9(2):17-22. <https://pmc.ncbi.nlm.nih.gov/articles/PMC10874479/>.
49. [△]Lei J, Xiao W, Zhang J, Liu F, Xin C, Zhou B, et al. Antifungal activity of vitamin D3 against *Candida albicans* in vitro and in vivo. *Microbiological Research*. 2022 Dec;265:127200. doi:10.1016/j.micres.2022.127200.
50. [△]Jawhara S. How Gut Bacterial Dysbiosis Can Promote *Candida albicans* Overgrowth during Colonic Inflammation. *Microorganisms*. 2022;10(5):1014. doi:10.3390/microorganisms10051014.
51. [△]Thomas RL, Jiang L, Adams JS, Xu ZZ, Shen J, Janssen S, et al. Vitamin D metabolites and the gut microbiome in older men. *Nature Communications*. 2020;11:5997. doi:10.1038/s41467-020-19793-8.
52. [△]Tangestani H, Boroujeni HK, Djafarian K, Emamat H, Shab-Bidar S. Vitamin D and The Gut Microbiota: a Narrative Literature Review. *Clinical Nutrition Research*. 2021 Jul;10(3):181-191. doi:10.7762/cnr.2021.10.3.181.
53. [△]Singh P, Rawat A, Alwakeel M, Sharif E, Al Khodor S. The potential role of vitamin D supplementation as a gut microbiota modifier in healthy individuals. *Scientific Reports*. 2020;10:21641. doi:10.1038/s41598-020-77806-4.
54. [△]Giampazolias E, Pereira da Costa M, Lam KC, Lim KHJ, Cardoso A, Piot C, et al. Vitamin D regulates microbiome-dependent cancer immunity. *Science*. 2024;384:428-437. doi:10.1126/science.adh7954.

55. [△]Yamamoto EA, Jørgensen TN. Relationships Between Vitamin D, Gut Microbiome, and Systemic Autoimmunity. *Frontiers in Immunology*. 2020 Jan 21;10:3141. doi:10.3389/fimmu.2019.03141.
56. [△]Tabatabaeizadeh SE, Tafazoli N, Ferns GA, Avan A, Ghayour-Mobarhan M. Vitamin D, the gut microbiome and inflammatory bowel disease. *Journal of Research in Medical Sciences*. 2018;23(1):75. doi:10.4103/jrms.JRMS_606_17.
57. [△]Kanhere M, He J, Chassaing B, Ziegler TR, Alvarez JA, Ivie EA, et al. Bolus Weekly Vitamin D3 Supplementation Impacts Gut and Airway Microbiota in Adults With Cystic Fibrosis: A Double-Blind, Randomized, Placebo-Controlled Clinical Trial. *The Journal of Clinical Endocrinology & Metabolism*. 2018;103(2):564-574. doi:10.1210/jc.2017-01983.
58. [△]Cantarel BL, Waubant E, Chehoud C, Kuczynski J, DeSantis TZ, Warrington J, et al. Gut microbiota in multiple sclerosis: possible influence of immunomodulators. *Journal of Investigative Medicine*. 2015 Jun;63(5):729-734. doi:10.1097/JIM.000000000000192.
59. [△]Velizarova M, Yanachkova V, Boneva T, Giragosyan S, Mihaleva I, Andreeva-Gateva P, et al. Relationship between Vitamin D status and microbiome changes in Bulgarian patients with type 2 diabetes mellitus. *Biotechnology & Biotechnological Equipment*. 2023;37(1). doi:10.1080/13102818.2023.2209662.
60. [△][‡]Daley DK, Myrie SB. Diabetes and vitamin D: The effect of insulin sensitivity and gut microbial health. *Advances in Food and Nutrition Research*. 2024;109:160-184. doi:10.1016/bs.afnr.2024.04.001.
61. [△]Breuling M, Tomeva E, Ivanovic N, Haslberger A. Butyrate- and Beta-Hydroxybutyrate-Mediated Effects of Interventions with Pro- and Prebiotics, Fasting, and Caloric Restrictions on Depression: A Systematic Review and Meta-Analysis. *Life*. 2024; 14(7):787. doi:10.3390/life14070787.
62. [△]Wang C, Zheng D, Weng F, Jin Y, He L. Sodium butyrate ameliorates the cognitive impairment of Alzheimer's disease by regulating the metabolism of astrocytes. *Psychopharmacology*. 2022; 239:215-227. doi:10.1007/s00213-021-06025-0.
63. [△]Chen J, Zhao K-N, Vitetta L. Effects of Intestinal Microbial-Elaborated Butyrate on Oncogenic Signaling Pathways. *Nutrients*. 2019; 11(5):1026. doi:10.3390/nu11051026.
64. [△]Zhang Y, Tao Y, Gu Y, Ma Q. Butyrate facilitates immune clearance of colorectal cancer cells by suppressing STAT1-mediated PD-L1 expression. *Clinics (Sao Paulo)*. 2023; 78:100303. doi:10.1016/j.clinsp.2023.100303.
65. [△]Coppola S, Avagliano C, Calignano A, Berni Canani R. The Protective Role of Butyrate against Obesity and Obesity-Related Diseases. *Molecules*. 2021; 26(3):682. doi:10.3390/molecules26030682.

66. [△]Blaak EE, Canfora EE, Theis S, Frost G, Groen AK, Mithieux G, et al. Short chain fatty acids in human gut and metabolic health. *Benef Microbes*. 2020; 11(5):411–455. <https://doi.org/10.3920/BM2020.0057>
67. [△]Facchin S, Bertin L, Bonazzi E, Lorenzon G, De Barba C, Barberio B, et al. Short-Chain Fatty Acids and Human Health: From Metabolic Pathways to Current Therapeutic Implications. *Life*. 2024; 14(5):559. doi:10.3390/life14050559.
68. [△]Charoenngam N, Shirvani A, Kalajian TA, Song A, Holick MF. The Effect of Various Doses of Oral Vitamin D3 Supplementation on Gut Microbiota in Healthy Adults: A Randomized, Double-blinded, Dose-response Study. *Anticancer Res*. 2020; 40(1):551–556. doi:10.21873/anticancerres.13984.
69. [△]Cooney OD, Nagareddy PR, Murphy AJ, Lee MKS. Healthy Gut, Healthy Bones: Targeting the Gut Microbiome to Promote Bone Health. *Front Endocrinol (Lausanne)*. 2021; 11:620466. doi:10.3389/fendo.2020.620466.
70. [△]Pacifici R. Role of Gut Microbiota in the Skeletal Response to PTH. *The Journal of Clinical Endocrinology & Metabolism*. 2021; 106(3):636–645. doi:10.1210/clinem/dgaa895.
71. [△]Su D, Nie Y, Zhu A, Chen Z, Wu P, Zhang L, et al. Vitamin D Signaling through Induction of Paneth Cell Defensins Maintains Gut Microbiota and Improves Metabolic Disorders and Hepatic Steatosis in Animal Models. *Front Physiol*. 2016; 7:498. doi:10.3389/fphys.2016.00498.
72. [△]Hansdah K, Lui JC. Emerging Insights into the Endocrine Regulation of Bone Homeostasis by Gut Microbiome. *Journal of the Endocrine Society*. 2024; 8(8):bvae117. doi:10.1210/jendso/bvae117.
73. [△]Rinninella E, Raoul P, Cintoni M, Franceschi F, Miggianno GAD, Gasbarrini A, Mele MC. What is the Healthy Gut Microbiota Composition? A Changing Ecosystem across Age, Environment, Diet, and Diseases. *Microorganisms*. 2019; 7(1):14. doi:10.3390/microorganisms7010014.
74. [△][‡]Bellerba F, Muzio V, Gnagnarella P, Facciotti F, Chiocca S, Bossi P, et al. The Association between Vitamin D and Gut Microbiota: A Systematic Review of Human Studies. *Nutrients*. 2021; 13(10):3378. doi:10.3390/nu13103378.
75. [△]Gominak SC. Vitamin D deficiency changes the intestinal microbiome reducing B vitamin production in the gut. The resulting lack of pantothenic acid adversely affects the immune system, producing a "pro-inflammatory" state associated with atherosclerosis and autoimmunity. *Med Hypotheses*. 2016; 94:103–107. doi:10.1016/j.mehy.2016.07.007.
76. [△]Wibowo S, Pramadhani A. Vitamin B, Role of Gut Microbiota and Gut Health. *IntechOpen*. 2024. doi:10.5772/intechopen.109485.

77. [△]Nysten J, Van Dijck P. Can we microbe–manage our vitamin acquisition for better health? *PLoS Pathog* ens. 2023; 19(5):e1011361. doi:10.1371/journal.ppat.1011361.
78. [△]Mansmann HC. Consider magnesium homeostasis: III: cytochrome P450 enzymes and drug toxicity. *Applied Immunohistochemistry & Molecular Morphology*. 1994; 8:7–28. <https://www.liebertpub.com/doi/abs/10.1089/pai.1994.8.7>
79. [△]Collins SL, Stine JG, Bisanz JE, Okafor CD, Patterson AD. Bile acids and the gut microbiota: metabolic interactions and impacts on disease. *Nat Rev Microbiol*. 2023; 21:236–247. doi:10.1038/s41579-022-00805-x.
80. [△]Ji S, Pan Y, Zhu L, Tan J, Tang S, Yang Q, et al. A novel 7 α -hydroxysteroid dehydrogenase: Magnesium i on significantly enhances its activity and thermostability. *Int J Biol Macromol*. 2021; 177:111–118. doi:10.1016/j.ijbiomac.2021.02.082.
81. [△]Kim DM, Liu J, Whitmore MA, Tobin I, Zhao Z, Zhang G. Two intestinal microbiota–derived metabolite s, deoxycholic acid and butyrate, synergize to enhance host defense peptide synthesis and alleviate necrotic enteritis. *J Animal Sci Biotechnol*. 2024; 15:29. doi:10.1186/s40104-024-00995-9.
82. ^a, ^bOjo ES, Tischkau SA. The Role of AhR in the Hallmarks of Brain Aging: Friend and Foe. *Cells*. 2021; 10(10):2729. <https://doi.org/10.3390/cells10102729>
83. [△]Wang Z, Snyder M, Kenison JE, Yang K, Lara B, Lydell E, et al. How the AhR Became Important in Cancer: The Role of Chronically Active AhR in Cancer Aggression. *International Journal of Molecular Sciences*. 2020; 22(1):387. doi:10.3390/ijms22010387.
84. [△]Zhu K, Meng Q, Zhang Z, Yi T, He Y, Zheng J, et al. Aryl hydrocarbon receptor pathway: Role, regulation and intervention in atherosclerosis therapy (Review). *Molecular Medicine Reports*. 2019; 20(6):4763–4773. <https://doi.org/10.3892/mmr.2019.10748>
85. [△]Koper JEB, Kortekaas M, Loonen LMP, Huang Z, Wells JM, Gill CIR, et al. Aryl hydrocarbon Receptor activation during in vitro and in vivo digestion of raw and cooked broccoli (*brassica oleracea* var. *Italica*). *Food Funct*. 2020; 11(5):4026–4037. doi:10.1039/d0fo00472c.
86. [△]Marinelli L, Martin–Gallausiaux C, Bourhis JM, Béquet–Crespel F, Blottière HM, Lapaque N. Identification of the novel role of butyrate as AhR ligand in human intestinal epithelial cells. *Sci Rep*. 2019; 9:643. doi:10.1038/s41598-018-37019-2.
87. [△]Li X, Zhang B, Hu Y, Zhao Y. New Insights Into Gut–Bacteria–Derived Indole and Its Derivatives in Intestinal and Liver Diseases. *Front Pharmacol*. 2021; 12:769501. doi:10.3389/fphar.2021.769501.

88. [△]Gribble FM, Reimann F. Metabolic Messengers: glucagon-like peptide 1. *Nat Metab.* 2021; 3:142–148. doi:10.1038/s42255-020-00327-x.
89. [△]Chaudhary P, Kathuria D, Suri S, Bahndral A, Kanthi Naveen A. Probiotics- its functions and influence on the ageing process: A comprehensive review. *Food Bioscience.* 2023; 52:102389. <https://doi.org/10.1016/j.fbio.2023.102389>
90. [△], [▷], [◁]Mahboobi S, Ghasvarian M, Ghaem H, Alipour H, Alipour S, Eftekhari MH. Effects of probiotic and magnesium co-supplementation on mood, cognition, intestinal barrier function and inflammation in individuals with obesity and depressed mood: A randomized, double-blind placebo-controlled clinical trial. *Front Nutr.* 2022; 9:1018357. doi:10.3389/fnut.2022.1018357.
91. [△]Seefeldt JM, Homilius C, Hansen J, Lassen TR, Jespersen NR, Jensen RV, et al. Short-Chain Fatty Acid Butyrate Is an Inotropic Agent With Vasorelaxant and Cardioprotective Properties. *Journal of the American Heart Association: Cardiovascular and Cerebrovascular Disease.* 2024;13. doi:10.1161/JAHA.123.033744.
92. [△]Yu Z, Han J, Chen H, Wang Y, Zhou L, Wang M, et al. Oral Supplementation With Butyrate Improves Myocardial Ischemia/Reperfusion Injury via a Gut-Brain Neural Circuit. *Front Cardiovasc Med.* 2021 Sep 23;8:718674. doi:10.3389/fcvm.2021.718674.
93. [△]Sasaki H, Hayashi K, Imamura M, Hirota Y, Hosoki H, Nitta L, et al. Combined resistant dextrin and low-dose Mg oxide administration increases short-chain fatty acid and lactic acid production by gut microbiota. *J Nutr Biochem.* 2023 Oct;120:109420. doi:10.1016/j.jnutbio.2023.109420.
94. [△]Hou Y, Li J, Ying S. Tryptophan Metabolism and Gut Microbiota: A Novel Regulatory Axis Integrating the Microbiome, Immunity, and Cancer. *Metabolites.* 2023; 13(11):1166., an essential amino acid, also associated with longevity. Microbial short chain fatty acids (SCFAs), particularly butyrate, alter IDO expression, thereby reducing kynurenine production <https://doi.org/10.3390/ijms22062973>.
95. [△]Kherad Z, Yazdanpanah S, Saadat F, Pakshir K, Zomorodian K. Vitamin D3: A promising antifungal and antibiofilm agent against *Candida* species. *Curr Med Mycol.* 2023 Jun;9(2):17-22. <https://pubmed.ncbi.nlm.nih.gov/38375518/>.
96. [△], [▷]Campbell BM, Charych E, Lee AW, Möller T. Kynurenines in CNS disease: regulation by inflammatory cytokines. *Front Neurosci.* 2014 Feb 6;8:12. doi:10.3389/fnins.2014.00012.
97. [△], [▷]Louis P, Duncan SH, Sheridan PO, Walker AW, Flint HJ (2022). "Microbial lactate utilisation and the stability of the gut microbiome." *Gut Microbiome.* 3: e3. doi:10.1017/gmb.2022.3.
98. [△]Li, J., Yan, Y., Fu, Y. et al. ACE2 mediates tryptophan alleviation on diarrhea by repairing intestine barrier involved mTOR pathway. *Cell Mol Biol Lett* 29, 90 (2024). doi:10.1186/s11658-024-00603-8.

99. [△]Wimalawansa SJ. *Physiology of Vitamin D—Focusing on Disease Prevention*. *Nutrients*. 2024; 16(11):1666. doi:10.3390/nu16111666.
100. [△]AlHewishel MA, Bahgat M, Al Huwaiyshil A, et al. (June 29, 2020) 25(OH) D Serum Level in Non-Diabetic and Type II Diabetic Patients: A Cross-Sectional Study. *Cureus* 12(6): e8910. doi:10.7759/cureus.8910.
101. [△]Abraham GE, Schwartz UD, Lubran MM (1981) Effect of vitamin B-6 on plasma and red blood cell magnesium levels in premenopausal women. *Ann Clin Lab Sci* 11(4):333-336 <https://pubmed.ncbi.nlm.nih.gov/7271227>
102. [△]Boylan LM, Spallholz JE (1990) In vitro evidence for a relationship between magnesium and vitamin B-6. *Magnes Res* 3:79-85 <https://pubmed.ncbi.nlm.nih.gov/2133627>
103. [△]Planells E, Lerma A, Sánchez-Morito N, Aranda P, Llopis J (1997) Effect of magnesium deficiency on vitamin B2 and B6 status in the rat. *J Am Coll Nutr* 16(4):352-356. doi:10.1080/07315724.1997.10718697.
104. [△]Noah L, Pickering G, Dubray C, Mazur A, Hitier S, et al. (2020) Effect of vitamin B6 supplementation, in combination with magnesium, on severe stress and magnesium status: Secondary analysis from an RCT. *Proceedings of the Nutrition Society* 79(OCE2), E491. doi:10.1017/S0029665120004395.
105. [△]Pouteau E, Kabir-Ahmadi M, Noah L, Mazur A, Dye L, et al. (2018) Superiority of magnesium and vitamin B6 over magnesium alone on severe stress in healthy adults with low magnesemia: A randomized, single-blind clinical trial. *PLOS ONE* 13(12):e0208454. doi:10.1371/journal.pone.0208454.
106. [△]Ohsu T, Amino Y, Nagasaki H, Yamanaka T, Takeshita S, Hatanaka T, et al. (January 2010). Involvement of the calcium-sensing receptor in human taste perception. *The Journal of Biological Chemistry*. 285(2): 1016-1022. doi:10.1074/jbc.m109.029165.
107. [△]Pickering G, Mazur A, Trousselard M, Bienkowski P, Yaltsewa N, Amessou M, Noah L, Pouteau E. *Magnesium Status and Stress: The Vicious Circle Concept Revisited*. *Nutrients*. 2020 Nov 28;12(12):3672. doi:10.3390/nu12123672.
108. [△]Akimbekov NS, Digel I, Sherelkhan DK, Lutfor AB, Razzaque MS. *Vitamin D and the Host-Gut Microbiome: A Brief Overview*. *Acta Histochem Cytochem*. 2020 Jun 26;53(3):33-42. doi:10.1267/ahc.20011.

Declarations

Funding: No specific funding was received for this work.

Potential competing interests: No potential competing interests to declare.