

# Performance Evaluation and Analysis of Electric Vehicle Parameters – A Test Bench

K. Vijayakumar<sup>1</sup> S.Kannan<sup>2</sup>

<sup>1</sup>Associate Professor, Department of Electrical and Electronics Engineering  
Kalasalingam Academy of Research and Education, Krishnankoil, India  
k.vijayakumar@klu.ac.in

<sup>2</sup>Professor & Head, Department of Electrical and Electronics Engineering  
Ramco Institute of Technology, Rajapalayam, India

**Abstract** – In the current scenario, an electric vehicle (EV) has significant growth potential, with India's GDP predicted to expand by 25% by 2024. We can improve the reliability of electric cars by correctly assessing their parameters and studying their characteristics. We can also make EVs more cost-effective by tailoring the design of electric vehicle components to consider the driving cycle and vehicle attributes. In this study, the real critical parameters and driving cycle data were considered in order to develop a more advanced model. This research looked into the effects of several factors on vehicle performance and energy usage. This study establishes an effective method for determining the suitable motor rating and battery capacity for an EV. This work also acts as a test bed for EV manufacturers and consumers to estimate and assess car performance in order to improve the design or functionality.

**Index Terms** – Electric Vehicle, Driving cycle, State of Charging, MATLAB Simulink, and Cloud.

## I. INTRODUCTION

The electric vehicle has been becoming popular since 2010. Almost 1 million electric cars were sold globally in 2016, 4.8 million cars were sold by 2019, and 10 million units were sold by 2020. India's GDP is expected to grow by 25 % by 2022 in the E-Mobility market by reducing crude oil imports by \$60 billion. The overall fuel cost of about Twenty thousand rupees is reduced for every 5000 km by using an EV, i.e., 1.1 rupees per kilometre. This facilitates private car owners to switch to an EV. The EV propulsion system comprises electric motors that convert electrical energy into mechanical torque. The EV is categorized into three, namely i) an entirely battery-operated EV, ii) a solar-powered EV, and iii) a hybrid EV. There are a lot more manufacturers in the EV market, namely BMW, Hyundai, Mercedes-Benz, Audi, Nissan, Tesla, Peugeot, Renault, Venturi, and Volkswagen, some of the manufacturers of EVs with a top speed of 355km/hr. and an acceleration of 2.4 sec to 15.9 sec. The charging duration varies between 30 minutes and 12 hours with a minimum range of 40 km to 560 km, with the capability of 2 - 7 passengers [1]. The price variety of the EV mainly depends on speed, range, battery capacity and load.

A driving cycle, typically speed versus time, represents how a vehicle trips over a route (uphill or downhill or normal road).

This Driving cycle varies concerning vehicle parameters, electrical parameters, location parameters, etc. So, the continuous monitoring of those parameters can help select EV components such as batteries and motors. Monitoring EV parameters can prompt the manufacturer to optimize and customize the EV components according to the Driving cycle. Further, this monitoring of EV parameters on the vehicle side will assist the user in having a better experience with the vehicle.

## II. DRIVING CYCLES

The driving cycles are used to assess a vehicle's performance based on fuel, economy, and emission tests. To investigate the state of battery and energy consumption in Electric vehicles, the driving cycle inputs play a major role. Also, the selection of absolute motor rating and battery capacity for the particular driving cycle can be utilized in EVs for better vehicle efficiency. The driving cycles can also simulate the vehicle design prior to the actual progress. A drive cycle test is performed to understand the vehicle's energy use in a certain period along with different conditions of routes [9].

There are two driving cycles, the European standard NEDC, or Japanese 10-15 Mode and the transitory cycles, the FTP-75 or Artemis cycle [9]. The key difference is that NEDC cycles are a collation of straightforward acceleration and uniform speed periods and are not illustrative of actual driver behavior, while FTP-75 include several speed deviations.

### A. The European driving cycles:

In Europe and other countries, the NEDC (shown in Fig. 1) is used as a benchmark cycle for homologating automobiles until the Euro6 standard is implemented. It consists of a four-times-repeating urban part named ECE and an extra-urban part called EUDC. The important features of the cycle are that the distance is 11023m, the duration is 1180s, and the average speed is 33.6km/hr. Experts criticize this cycle as it does not signify real-life driving environments. Speeding up is certainly simple; there are numerous constant speed cruises and idle events. This makes obtaining certified values while driving in real-world situations impractical. European authorities are investigating a way to replace the NEDC for

these reasons. For the upcoming Euro7 standard, a new cycle known as the Worldwide Harmonized Light Vehicle Test Procedure (WLTP) may be introduced.

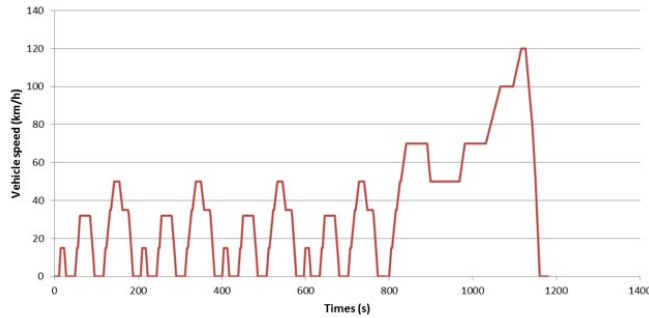

Fig. 1 Norm European Driving Cycle

*B. The Artemis driving cycle:*

This cycle is based on the findings of European statistical research conducted as part of the Artemis project. It comes with three distinct patterns, as well as an additional variant: the urban cycle, the rural cycle, the highway 130 km/hr, and the highway 150 km/hr. Figs. 2, 3, and 4 represent Artemis' urban, rural, and highway, respectively.

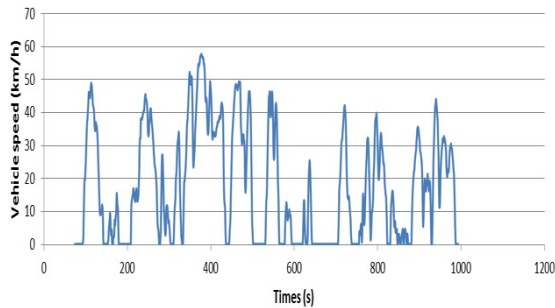

Fig. 2 Urban Artemis Cycle

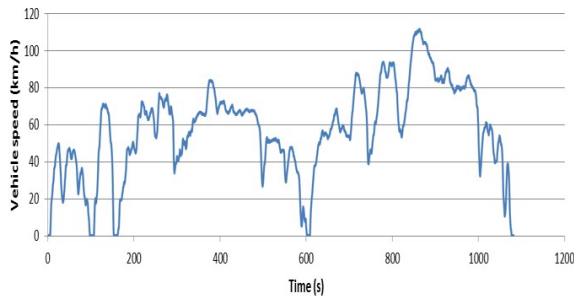

Fig.3 Artemis Rural Cycle

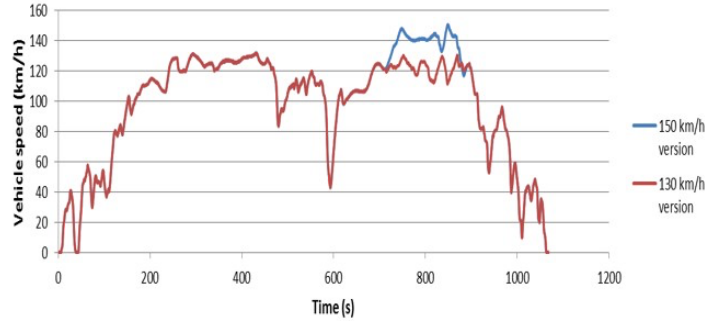

Fig.4 Artemis Highway Cycle

*C. Japanese driving cycles:*

For Japan's emissions and fuel consumption certification, the 10-15 mode Japanese cycle shown in Fig. 5 is used. It replicates urban and highway cycles, including idle times, as well as accelerating, cruising, and decelerating speeds. The measurements are taken while the engine is hot, using a conventional warming technique. Because this cycle has the same drawbacks as the NEDC, Japanese regulators and manufacturers opted to switch to the JC08 cycle in 2011.

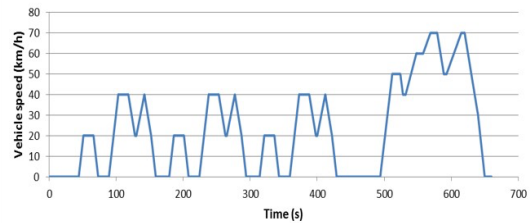

Fig.5 The 10-15 mode Japanese cycle

III.ELECTRIC VEHICLE

An Electric Vehicle is a traction system where the batteries provide the propulsion to attain its torque. The basic principle behind the EV is converting Electrical energy into Mechanical Energy utilizing a battery and motor. Most EVs use induction motors, permanent magnet synchronous motors, or switched reluctance motors to produce mechanical torque. Batteries are the next principal component and most overpriced component in EVs. Usually, Lithium-ion batteries or Zinc-air batteries are used as they have increased energy density (150-250 Wh/kg-1) compared to conventional lead-acid batteries like Ni-Cd or Ni-MH [3]. The EV comprises the following subsystem, shown in Fig 6.

All-Electric Vehicle

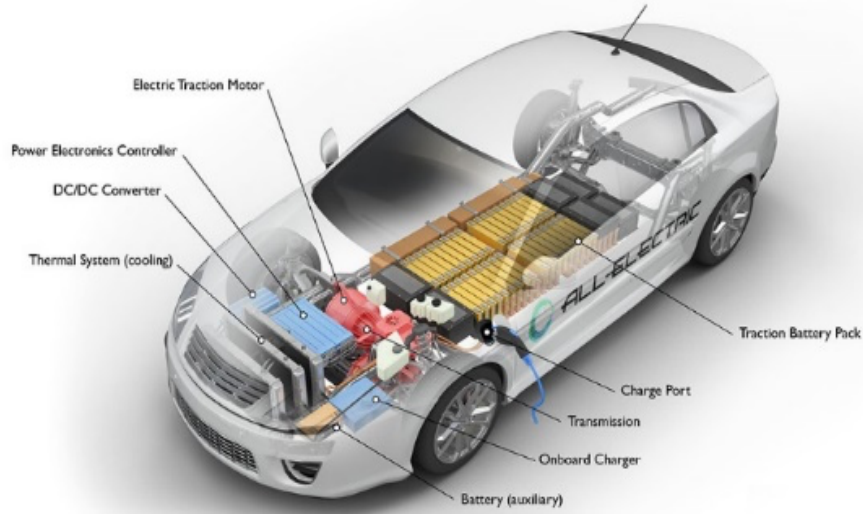

Fig. 6 EV subsystem

It has an Electric Traction Motor, Traction Battery Pack, Power Electronics Controller, DC/DC converter, Transmission, Onboard charger, Auxiliary Battery, Charge port, Thermal cooling system, etc.

IV.FUNCTIONAL EV SUBSYSTEMS

The Functional block diagram of the EV parameter estimation and analysis system is represented in Fig. 7. It consists of a Power train comprising subsystems, namely Vehicle Dynamics, Transmission, Motor and Battery. Hence, the simulation of the power train is divided into the Vehicle body, Motor and controller unit, Driver input and Battery pack, with the driving cycle being the input for the entire

power train. The various parameters associated with the power train, namely Wheel Torque, Wheel speed, Motor torque, Motor speed, Motor power and Battery power, are computed and analyzed. We can also compute the average speed of the electric vehicle. With the SOC's output, we can investigate battery charging and discharge during deceleration and acceleration, respectively [6]. The signal builder gives various parameters like acceleration, gradient, aerodynamic, and rolling force to find the total tractive force. This will help us figure out the battery state, which is changing concerning changes in other associated parameters of EV. Thus, we can come to an optimal solution through further studies. The overall EV simulation in MATLAB Simulink is represented in Fig. 8.

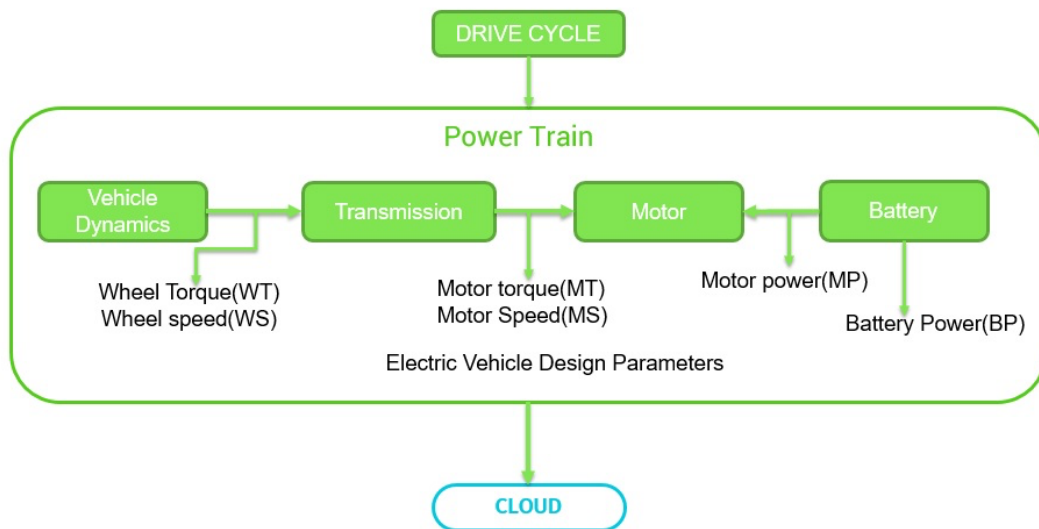

Fig. 7 Functional block diagram of EV parameter estimation and analysis system

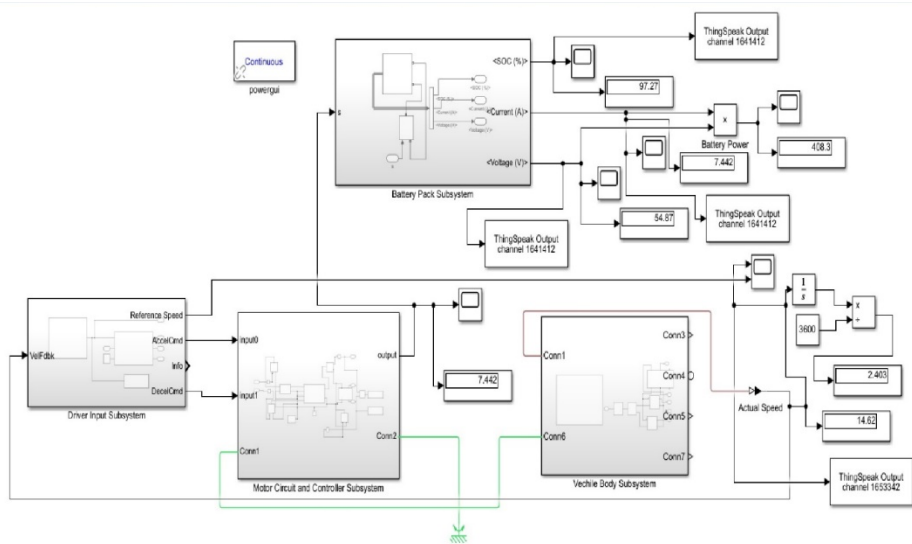

Fig. 8 Overall EV simulation in MATLAB Simulink

**A. Vehicle Body:**

The Vehicle body subsystem shown in Fig. 9 comprises differentials, gearbox, tire and vehicle body blocks from the Simscape library connected.

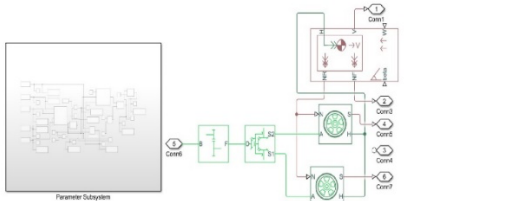

Fig. 9 Vehicle Body Subsystem

**B. Driver Input:**

The longitudinal driver block and Signal builder block in Fig. 10 create the driver input subsystem. Longitudinal driver blocks from the powertrain block library produce standardized acceleration and braking commands built on reference and feedback speeds. Reference velocity will be set by the built-in drive cycle, or we can create our signal by using the signal builder block. The Feedback speed will be obtained from the actual vehicle speed. The difference between the reference signal and the actual speed error will be created. The error thus created will result in acceleration or deceleration so that the vehicle's actual speed will match with the reference speed [6].

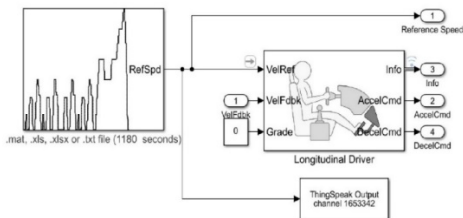

Fig. 10 Driver Input

**C. Battery Pack:**

This battery pack subsystem, shown in Fig. 11, will feed power to the motor. The State of Charge (SOC) is estimated by using this subsystem. The SOC data will help estimate how far we can drive before recharging and how long we can drive using the current battery charge, i.e., nothing but charging and discharging of batteries [5], [6].

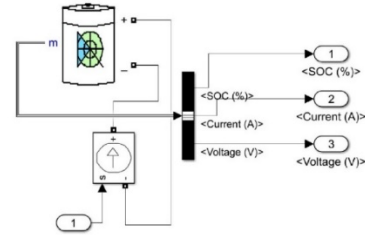

Fig. 11 Battery Subsystem

**D. Motor Circuit and Controller:**

As shown in Fig. 12, the essential part is where the conversion of electrical energy into mechanical energy occurs. This mechanical energy is supplied to the gearbox of the vehicle body. A Simple DC motor with an H Bridge controller triggered with PWM is used in the simulation to apply acceleration, deceleration and braking [5].

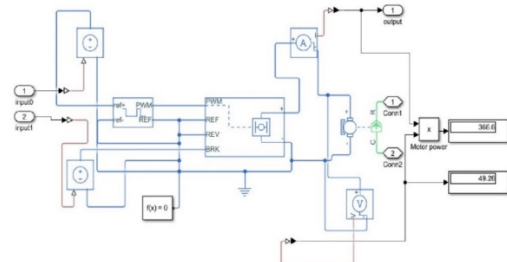

Fig. 12 Motor Circuit

## V. ELECTRIC VEHICLE DESIGN PARAMETERS

The design parameters of an electric vehicle include the Rolling coefficient, Vehicle mass, Driver mass, Grade angle, Area, Air density, Radius of the wheel, Gear ratio, Transmission efficiency, Motor efficiency, Gross vehicle mass, acceleration due to gravity, Gross vehicle weight, Motor controller efficiency, Drag coefficient, etc. [1]. The EV input parameters and drive cycle inputs given in the simulation are represented in Fig. 13. The vehicle parameters of Ather 450x are considered for the simulation analysis. The associated parameters analyzed are discussed in detail in other sections.

TABLE 1. ATHER 450X PARAMETERS

Input Parameters	Values	Units
Rolling coefficient	0.015	-
Vehicle Mass	111	Kg
Driver Mass	80	Kg
Grade ( $\phi$ )	0	$^{\circ}$
Area	0.875	$m^2$
Air Density	1.225	$Kg/m^3$
Radius of wheel	0.1524	m
Gear ratio	7.8	-
Transmission efficiency	0.85	-
Motor efficiency	0.9	-
GVM	191	Kg
Acceleration due to gravity	9.81	$m/s^2$
GVW	1873.71	N
Motor Controller efficiency	0.85	-
Drag coefficient	0.22	-

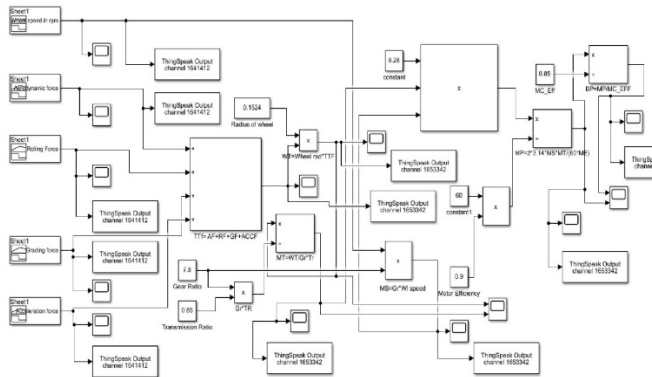

Fig. 13 EV Parameters and Driving Cycle Inputs

### A. Dynamics of the Vehicle

The Vehicle dynamics is nothing but the vehicle's motion because of the steering action. The Inertia comes into action, i.e., the resistance offered to the vehicle while trying to move from a stall state or accelerating state. To sustain the speed, the vehicle must overcome these resistive forces. So, all

these factors determine the speed of a moving vehicle. It affects the vehicle's performance and energy consumption per driven distance [2].

### B. Acceleration Force $FA(t)$ :

The accelerating force owing to vehicle motion in any given direction, according to Newton's second law of mechanics, is equal to the total of forces acting on the moving vehicle in the same direction, as given by the equations [9], [7].  $FA(t) = ma = m [dv(t)/dt] = Ft(t) - Fr(t)$

Where,  $FA(t)$  is the accelerating force in Newton N  
 $m$  is the mass in kg

$dv(t)/dt$  is the rate of change of vehicle speed in  $m/s^2$

$a$  is the acceleration in  $m/s^2$

$Ft(t)$  is the total of all tractive forces operating on the vehicle to raise its speed in Newton metres Nm.

The sum of all resistive forces operating on the vehicle to reduce its speed in Newton metres Nm is  $Fr(t)$ , which is shown in Fig. 14.

Uphill driving gravity, aerodynamic drag, rolling resistance, and regenerative braking are all responsible for the resistive force. Downhill driving gravity contributes to the tractive force. The vehicle's tractive force is transferred to the contact area between the wheel and the road via the wheel shaft, gear, and differential.

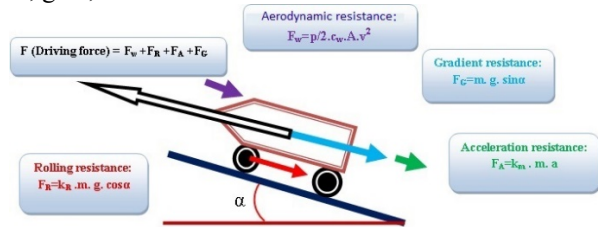

Fig. 14 Resistive forces acting on the vehicle

The Acceleration force acting on the vehicle concerning time is shown in Fig. 15

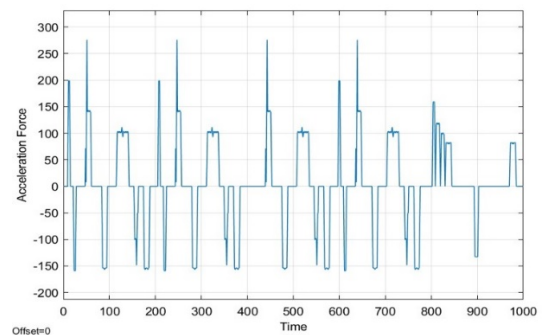

Fig. 15 Acceleration Force

### C. Aerodynamic Drag Force $FW(t)$ :

The air resistance or the aerodynamic drag is the resistive force acting on a moving body in the air medium [1]. Whenever the vehicle or a body moves in a dense medium, the molecules

strike with the body in motion, which resists the vehicle's speed. The density of the air is directly related to the resistance offered. Moreover, the speed of the moving body is directly proportional to the resistance. The Aerodynamic force acting on the vehicle is represented in Fig. 16. It is mathematically expressed as,

$$FW(t) = \frac{1}{2} \rho_a C_a A_e V^2$$

$$V^2 = (V_{\text{vehicle}} - V_{\text{wind}})^2$$

Where,

$\rho_a$  the air density in kg/m<sup>3</sup>, which varies according to temperature, humidity, pressure, altitude, etc. The standard air density at sea level with a temperature of 250 C in a normal atmospheric pressure of 1013.25 pascals is 1.225 kg/m<sup>3</sup>[1].

$C_a$  is the aerodynamic drag coefficient between 0.25-0.35 for a typical car.

$A_e$  is the vehicle cross-sectional area in m<sup>2</sup>, which varies for the vehicle mass and form.

The  $V_{\text{vehicle}}$  is the velocity of the vehicle in m/s

$V_{\text{wind}}$  is the velocity of wind in m/s

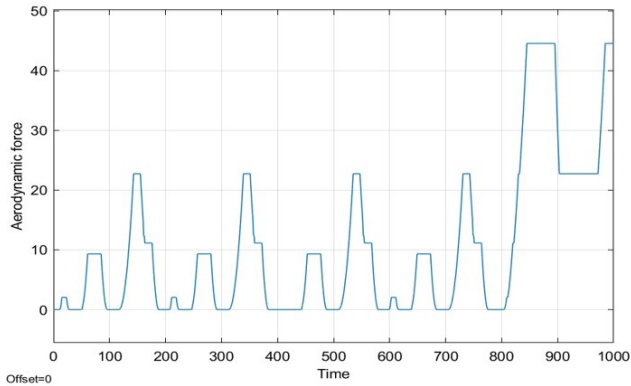

Fig. 16 Aerodynamic Force

#### D. Rolling Resistance Force $FR(t)$ :

Rolling resistance is one of the resistances offered to moving vehicles that roll on the road. The relative motion between the road and the tire produces friction, which resists the body's movement [1], [7]. Because there is a gradual distortion at the point of contact between the road and the tire, with the greatest distortion at the bottom-most point and the smallest distortion at the entry and exit points, the tire slips with respect to the road, resulting in another type of energy loss that causes resistance. The vehicle's rolling force is depicted in Fig. 17. This is mathematically expressed as,

$$FR(t) = Cr mg \cos(\alpha)$$

Where,

$Cr$  is the rolling resistance coefficient, which ranges from 0.007 to 0.015. This is a dimensionless quantity.

$m$  is the mass in kg

$g$  is the gravitational constant 9.807 in m/s<sup>2</sup>

$\alpha$  is the inclination angle of the road in radians.

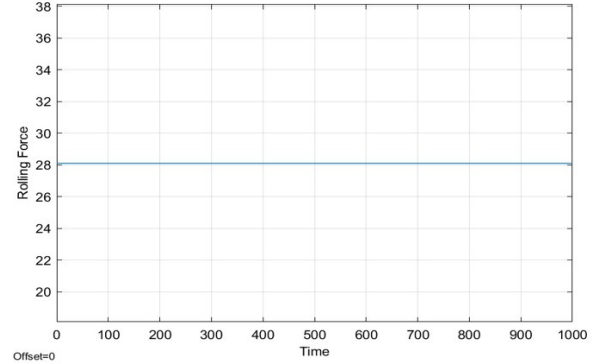

Fig. 17 Rolling Force

#### E. Gradient Resistance Force $FG(t)$ :

When a vehicle travels uphill, a portion of its weight exerts itself in the opposing direction of its motion. The vehicle will slow down, stall, and roll back if enough energy is not supplied to overcome the reverse force. If the car is trading uphill at a slope of, the vehicle's weight,  $W$ , has two components: one perpendicular to the road surface (with a value  $W \cdot \cos \theta$ ) and the other parallel to the road surface (with a value  $W \cdot \sin \theta$ ) [1]. The component that tries to obstruct motion is the one that runs down the road surface. The gradient resistance is calculated as follows:

$$FG(t) = mg \sin(\alpha)$$

$$\alpha = \tan^{-1}(dv/dh)$$

Where,

$\alpha$  is the angle in radians between the horizontal plane of the vehicle and the level road.

The perpendicular distance is  $dv$ , and the horizontal distance is  $dh$ .

For simulation purposes, the Gradient resistance force of the vehicle is assumed to be zero and is shown in Fig.18.

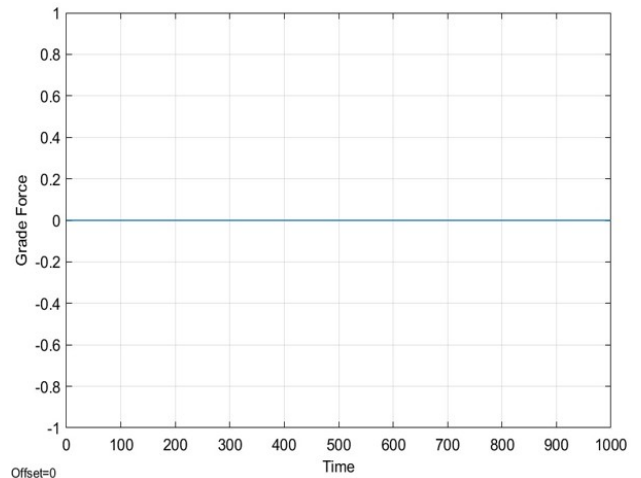

Fig. 18 Gradient Force

#### F. Total Tractive Force $F(t)$ :

It is the sum of accelerating force, gradient resistance

force, rolling resistance force and aerodynamic force exerted on the vehicle, which is mathematically represented as,

$$F(t) = F_A(t) + F_G(t) + F_R(t) + F_W(t)$$

From this, the Wheel torque of the vehicle is calculated by,

$$TW = F(t) * rw * \sin \theta$$

Where,

$F(t)$  is the Total Tractive Force in N

$rw$  is the wheel radius, and  $\theta$  is the angle formed by the road and the tire's point of contact.

The total tractive force exerted on the vehicle is represented in Fig. 19.

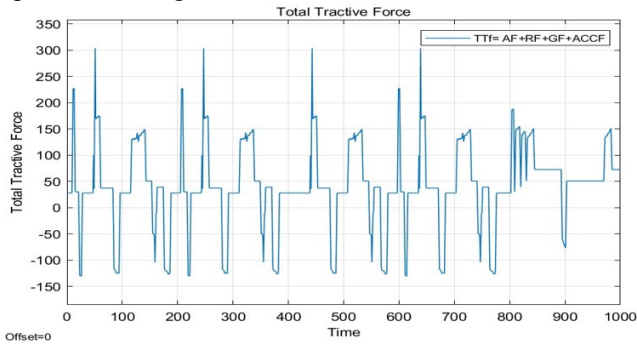

Fig. 19 Total Tractive Force

#### G. Motor Parameters:

The motor's torque ( $TM$ ) can be determined using the following formula.

$$TM = TW / (\text{Gear ratio} * \text{Transmission Efficiency})$$

Where  $TW$  stands for wheel torque, and  $TM$  stands for motor torque, both in Nm.

The Motor speed  $MS$  can be calculated using the relation

$$MS = \text{Gear Ratio} * \text{Wheel speed}$$

$$\text{Wheel speed} = \text{Velocity} * (60 / (2\pi * rw))$$

Where  $rw$  is the wheel radius.

The Motor power  $MP$  can be calculated using the relation

$$MP = (2\pi * MS * TM) / (60 * \text{Motor Efficiency})$$

The output of Motor torque versus time for the vehicle is represented in Fig.20.

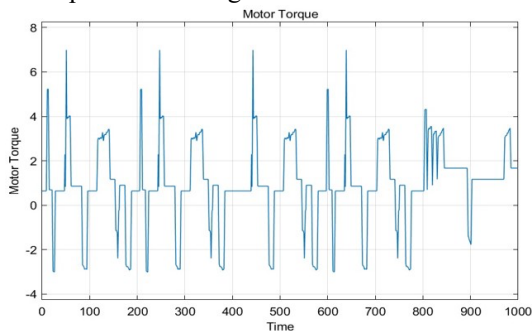

Fig. 20 Motor Torque vs Time

The output of wheel speed versus time is depicted in Fig. 21.

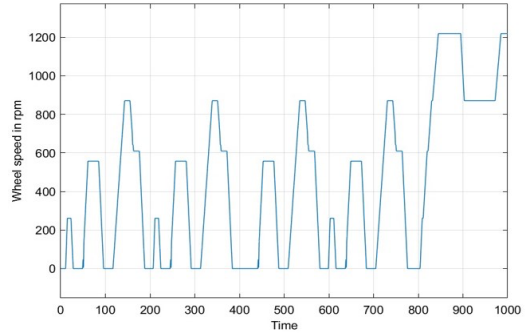

Fig. 21 Wheel Speed vs Time

#### H. Battery Parameters:

EV propulsion systems can use a variety of batteries. Despite this, Lithium-ion batteries are used in the majority of electric vehicles due to their higher specific energy [Wh/kg] and specific power [W/kg]. The maximum electrical power that can be supplied to EVs is determined by the voltage level of the battery. The diameter of the wires should be large to carry a higher current, resulting in higher thermal losses. To reduce thermal losses, the current should be controlled, and the minimum power can be reached by using a higher voltage [4]. Battery power = Motor power  $MP$  / Motor Controller efficiency  $MC_{eff}$

Where,

$MP$ -Motor power

##### I. $MC_{eff}$ -Motor Controller Efficiency

The output of the Battery current is represented in Fig. 22. The battery Voltage and Power are represented in Fig. 23 and 24, respectively. From the obtained outputs and the relative divergence among them corresponding to the driving cycle and vehicle parameters, it is evident that this serves as a test bench for an electric vehicle manufacturer as well as a user to estimate and analyze the performance of the vehicle for the betterment of the design or user experience.

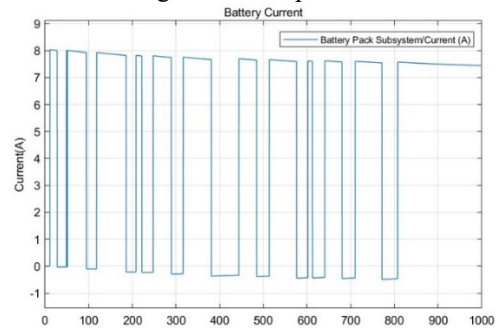

Fig. 22 Battery Current

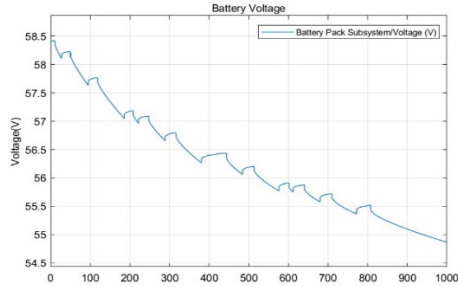

Fig. 23 Battery Voltage

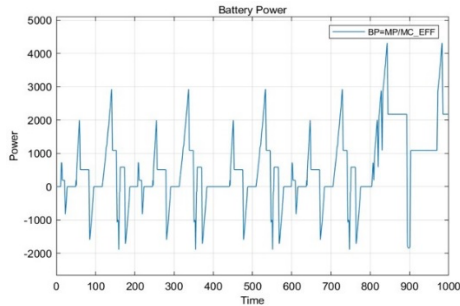

Fig. 24 Battery Power

The output of the State of Charging is represented in Fig.25, which facilitates the user's understanding of the SOC of the battery, and with that, the range of the vehicle can be estimated based on the driver's input.

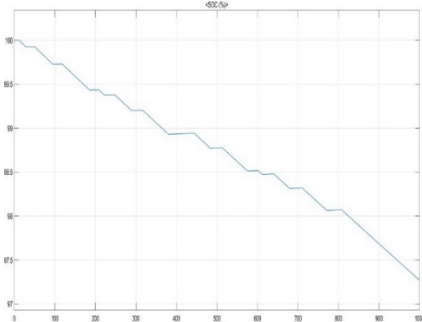

Fig. 25 SOC

## VI.CLOUD-BASED ESTIMATION

The performance parameters of the vehicle are aggregated, visualized and analyzed either historically or live using an IOT analytics platform service, namely ThingSpeak, in this work. The EV simulation in MATLAB is executed in ThingSpeak to perform online analysis and data processing. This cloud-based estimation of EV performance serves as prototyping and proof of concept for the EV manufacturer for performance evaluation. The ThingSpeak output of fields SOC, Battery Current, Voltage and Wheel Speed is represented in Fig. 26.

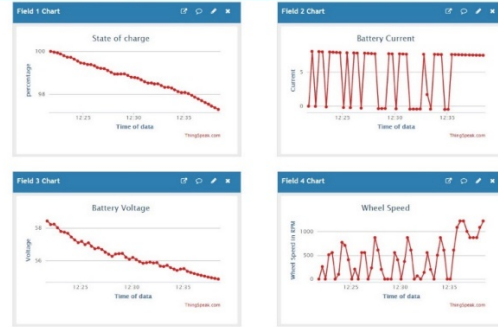

Fig. 26 ThingSpeak output of fields SOC, Battery Current, Voltage and Wheel Speed

## VII.CONCLUSION

Using this model, we can analyze the battery and motor performance of the EV. By changing the vehicle and electrical parameters, the various characteristics curves for the vehicle can be obtained, which shows that design optimization is possible in the aspect of the choice of EV components for performance improvements. Further, the cloud-based estimation of EV performance serves as prototyping and proof of concept for the EV manufacturer for performance evaluation. The impact of various parameters on vehicle performance and energy consumption is manifested in this work.

## REFERENCES

- [1]. Reddy, K. S., & Veeranna, S. B. (2020). Design Parameters of Electric Vehicle. *2020 International Conference on Power Electronics & IoT Applications in Renewable Energy and its Control (PARC)*, 14-21. <https://doi.org/10.1109/PARC49193.2020.236548>.
- [2]. Mruzek, M., Gajdác, I., Kučera, L., & Barta, D. (2016). Analysis of Parameters Influencing Electric Vehicle Range. *Procedia Engineering*, 134, 165-174.
- [3]. Drosu, G., Suci, A., Scheianu, A., & Petre, I. (2019). An Analysis of Hybrid/Electric Vehicle Monitoring Systems and Parameters. *2019 Electric Vehicles International Conference (EV)*, 1-5. <https://doi.org/10.1109/EV.2019.8892923>.
- [4]. Loganathan, M. K., Tan, C. M., Sultana, S., Hsieh, I-Y. L., Kumaraswamidhas, L. A., & Ray, R. N. (2021). Parametric performance analysis of battery-operated electric vehicle. *2021 International Conference on Sustainable Energy and Future Electric Transportation (SEFET)*, 1-6. <https://doi.org/10.1109/SeFet48154.2021.9375788>.
- [5]. Eddahech, O., Briat, O., & Vinassa, J. (2012). Real-time SOC and SOH estimation for EV Li-ion cell using online parameters identification. *2012 IEEE Energy Conversion Congress and Exposition (ECCE)*, 4501-4505. <https://doi.org/10.1109/ECCE.2012.6342209>.
- [6]. Chatterjee, P., Singh, J., Singh, R., Avadh, Y. A. R., & Kanchan, S. (2021). Electric Vehicle Modeling in MATLAB and Simulink with SoC & SoE Estimation of a Lithium-ion Battery. *IOP Conference Series: Materials Science and Engineering*, 1116, 012103.
- [7]. Varga, B. O., Sagoian, A., & Mariasiu, F. (2019). Prediction Of Electric Vehicle Range: A Comprehensive Review Of Current Issues And Challenges. *Energies*, 12(5), 946.
- [8]. Hristov, P., Zahariev, P., Borisov, S., & Kyuchukova, D. (2016). An educational system for real-time monitoring and evaluation of the parameters of electric vehicles. *2016 15th International Conference on Information Technology Based Higher Education and Training (ITHET)*, 1-5. <https://doi.org/10.1109/ITHET.2016.7760757>.
- [9]. Parekh, V., & Shah, V. (2015). Measurement and Analysis of Indian Road Drive Cycles for Efficient and Economic Design of HEV Component. *World Electric Vehicle Journal*, 7(1), 121-132.